

AMHERST TOWN COUNCIL
AGENDA – WEDNESDAY, MAY 13, 2020
Meeting at 7:00 p.m.
Town Hall, 174 S. Main Street, Amherst, VA 24521

- A. Call to Order for the Town Council– 7:00 p.m. - Mayor Tuggle**
- B. Pledge of Allegiance** - *I pledge allegiance to the Flag of the United States of America, and to the Republic for which it stands, one Nation under God, indivisible, with liberty and justice for all.*
- C. Invocation-** *Any invocation that may be offered before the official start of the Amherst Town Council meeting shall be the voluntary offering to, and for, the benefit of the Council. The views or beliefs expressed by the invocation speaker have not been previously reviewed or approved by Council and do not necessarily represent the religious beliefs or views of the Council in part or as a whole. No member of the audience is required to attend or participate in the invocation, and such decision will have no impact on their right to participate actively in the business of the Council. Copies of the policy governing invocations and setting forth the procedure by which a volunteer may deliver an invocation are available upon request at the Town Hall.*
- D. Public Hearings and Presentations**
- 1. Public Hearing on the FY 20-21 Budget *CONTINUED*** - *The proposed budget was included in last month’s packet. The public hearing has been continued to allow citizen input in regard to budget concerns related to COVID-19 and impacts on the Town finances. Staff now recommends adoption on June 10, 2020. Revised numbers will be provided to Council and the public at the end of May.*
- E. Citizen Comments –** *This time is set aside on the agenda for Town citizens to address Council regarding items not on the agenda for public hearing or presentations. Individual comment time is limited to three minutes, and groups are limited to five minutes. This time is for citizens to address Council, and not designed to be a question and answer session or a discussion time. If follow-up is requested, that will occur after the meeting. Citizen comments must be submitted in advance of the meeting, no later than 6:45 pm. Comments have been solicited via Facebook and the Town’s website.*
- F. Consent Agenda –** *Items on the consent agenda can be voted on as a block if all are in agreement with the recommended action or discussed individually.*
- 1. Town Council Minutes (Pgs. 1-47) –** *Draft of the April 8, 2020 meeting minutes are **attached**. Please let Vicki Hunt know of any concerns by Wednesday morning such that any needed corrections can be presented at the meeting.*
- G. Correspondence and Reports**
- 1. Staff Reports (Pgs. 48-58)**
- a. Town Manager Monthly Report - **attached**
 - b. Police Chief Monthly Report - **attached**
 - c. Office Manager Monthly Report - **attached**
 - d. Clerk of Council Monthly Report- **attached**
 - e. Public Works Monthly Reports- **attached**
 - f. Town Attorney Monthly Report – **attached**
- 2. Council Committee Reports (Pg. 59-60)**
- a. Finance Committee – *Mrs. Carton*
 - b. Community Relations – *Mrs. Ogden*
 - c. Utilities Committee – *Mr. Watts- report regarding award of bids and contract execution and request for expenditure for construction stakeout.*
- 3. Other Reports (Pgs. 61-62)**

- a. Planning Commission, no May meeting
- b. Industrial Development Authority, met May 4, 2020, minutes attached.
- c. Robert E. Lee SWCD

H. Discussion Items

- 1. Request from IRON LIVES for a new date for the IRON 5k (Pgs 63)- Sara Carter-** *Due to the Coronavirus, the IRON Lives 5k was postponed from its April 19th date. The group is requesting a change to October 4th, 2020 for the event.*
- 2. Memorandum of Understanding with the Amherst County School Board (Pgs. 64-67)- Sara Carter-** *The School Board has approved the Memorandum of Understanding drafted by Mr. Berry for the Town's use of the sewer right of way between the Town park and South Main Street, along the edge of the high school property, for use as a recreational trail.*
- 3. Second Stage Request (Pgs. 68-69)- Sara Carter-** *Second Stage was unable to complete their planned programming due to the Coronavirus. They are requesting that Council allow them to receive their annual contribution without providing receipts for the planned expenses.*
- 4. Set public hearing for sale of property (Pgs. 70)- Sara Carter-** *The Town owns an approximate one acre parcel of land between Whitehead Drive and Maple Lane, which was previously used as a pump station. That pump station no longer exists and the Town has no need to retain the property, though it does need easements for lines across it. An adjacent owner is interested in purchasing it. A public hearing is required for the sale or lease of public land.*
- 5. Set public hearing for Sign Ordinance amendment to allow works of art (Pgs. 71-77)- Sara Carter-** *The Amherst County Chamber of Commerce has reached out to the Town about having a LOVE sign at the Visitor's Center. Staff recommends amending the ordinance to allow for this type of signage under a "works of art" section. Other localities have included this in their ordinances.*
- 6. Appointments to Boards (Pgs. 53)- Sara Carter-** *There are multiple reappointments and vacancies. Please see the Clerk of Council report for highlighted positions. June Driskill (Planning Commission), Glenda Hash and Manly Rucker (Property Maintenance Board) have all indicated that they are willing to continue to serve. Gary Mays (Board of Zoning Appeals) does not wish to serve again.*
- 7. Amendment to Comprehensive Plan for conservation easement at the Amherst Milling Company-** *Sara Carter- Action on this item has been deferred since the December meeting. The last deferral request by the applicant was to the April meeting.*

I. Matters from Staff

J. Matters from Town Council

K. Anticipated Town Council Agenda Items for Next Month

L. Citizen Comments

M. Adjournment

Mayor D. Dwayne Tuggle called a regular monthly meeting of the Amherst Town Council to order on April 8, 2020, at 7:04 P.M. in the Council Chambers of the Town Hall at 174 S. Main Street. It was noted that a quorum was present as follows:

P	D. Dwayne Tuggle	P	Kenneth G. Bunch
P	Rachel A. Carton	P	Sarah B. Ogden
P	Kenneth S. Watts	P	Janice N. Wheaton

Also present were the following staff members:

Sara E. Carter	Town Manager	Vicki K. Hunt	Clerk of Council
----------------	--------------	---------------	------------------

As a result of COVID-19 cautionary restrictions and limited space the above council members and staff met in person and electronically via virtual meeting in the event persons wishing to avoid attending could still address Council from home as part of a public hearing.

The following staff members were present electronically via virtual meeting:

Tracie Wright	Office Manager	Becky L. Cash	Lead Water Operator
---------------	----------------	---------------	---------------------

Recitation of the Pledge of Allegiance to the Flag was followed by an invocation by Kenneth S. Watts.

Mayor Tuggle opened a duly advertised public hearing on the Town’s proposed FY20/21 budget at 7:07 P.M. There being no one present in person or electronically who wished to speak on the budget matter, the public hearing closed at 7:08 P.M. After a report by Town Manager Carter, by consensus of Council, the public hearing was continued to the May 13, 2020, meeting to allow time for anticipated revisions due to changing economic conditions, with adoption of the budget on June 10, 2020, as recommended by staff.

Mayor Tuggle opened a duly advertised public hearing at 7:09 P.M. on the Town’s 2020-2021 Capital Improvement Program that identifies acquisition, construction and improvement of town facilities, and acquisition of capital equipment. Town Manager Carter gave a brief report on the Town’s 2020-2021 Capital Improvement Program as recommended on March 13, 2020, by the Planning Commission for approval by Town Council. There being no one present in person or electronically who wished to speak on the Capital Improvement Program proposal, the public hearing closed at 7:10 P.M.

Mr. Watts made a motion that was seconded by Mr. Bunch to adopt the 2020-2021 Capital Improvement Program that identifies acquisition, construction and improvement of town facilities, and acquisition of capital equipment, as recommended by the Planning Commission and staff. There being no discussion, the motion 4-1 via the roll call method carried as follows:

D. Dwayne Tuggle		Kenneth G. Bunch	Aye
Rachel A. Carton	Aye	Sarah B. Ogden	Aye
Kenneth S. Watts	Aye	Janice N. Wheaton	Nay

Mayor Tuggle opened a duly advertised public hearing on a proposed resolution authorizing the issuance of a general obligation and sewer revenue bond in a principal amount not to exceed \$3,414,000 and providing for the form and details thereof at 7:11 p.m. There being no one present in person or electronically who wished to speak, the public hearing closed at 7:12 pm.

After a report by Town Manager Carter, Ms. Carton made a motion that was seconded by Ms. Ogden to approve the proposed resolution authorizing the issuance of a general obligation and sewer revenue bond in a principal

amount not to exceed \$3,414,000 and providing for the form and details thereof, as recommended by staff. There being no discussion, the motion 4-1 via the roll call method carried as follows:

D. Dwayne Tuggle		Kenneth G. Bunch	Aye
Rachel A. Carton	Aye	Sarah B. Ogden	Aye
Kenneth S. Watts	Aye	Janice N. Wheaton	Nay

A copy of the Resolution is attached to and made a part of these minutes.

No citizen comments were made.

Mr. Watts made a motion that was seconded by Mr. Bunch to approve the minutes from the March 11, 2020, meeting. There being no discussion, the motion 3-1-1 via the roll call method carried as follows:

D. Dwayne Tuggle		Kenneth G. Bunch	Aye
Rachel A. Carton	Abstain	Sarah B. Ogden	Aye
Kenneth S. Watts	Aye	Janice N. Wheaton	Nay

Ms. Carton, on behalf of the Finance Committee, and Town Manager Carter gave a report on determination by Virginia Department of Taxation of 2012-2014 franchise tax refund owed to BB&T, now Truist, in the amount of \$32,277.00. Upon recommendation of the Finance Committee, Town Council voted to approve payment in the amount of \$32,277.00 to BB&T, now Truist, for 2012-2014 franchise tax refund, and authorize staff to make payment on or before May 1, 2020. There being no discussion, the motion 4-1 via the roll call method carried as follows:

D. Dwayne Tuggle		Kenneth G. Bunch	Aye
Rachel A. Carton	Aye	Sarah B. Ogden	Aye
Kenneth S. Watts	Aye	Janice N. Wheaton	Nay

Mr. Watts made a motion that was seconded by Ms. Carton to approve a Proclamation declaring April 10, 2020, Day of Prayer, as recommended by staff. There being no discussion, the motion 5-0 via the roll call method carried as follows:

D. Dwayne Tuggle		Kenneth G. Bunch	Aye
Rachel A. Carton	Aye	Sarah B. Ogden	Aye
Kenneth S. Watts	Aye	Janice N. Wheaton	Aye

Ms. Carton made a motion that was seconded by Mr. Bunch to adopt an Emergency Ordinance to Effect Temporary Changes in Certain Deadlines and to Modify Public Meeting Hearing Practices and Procedures to Address Continuity of Operations Associated with Pandemic Disaster, as recommended by staff. There being no discussion, the motion 5-0 via the roll call method carried as follows:

D. Dwayne Tuggle		Kenneth G. Bunch	Aye
Rachel A. Carton	Aye	Sarah B. Ogden	Aye
Kenneth S. Watts	Aye	Janice N. Wheaton	Aye

A copy of the Ordinance is attached to and made a part of these minutes.

Mr. Watts made a motion that was seconded by Ms. Ogden to adopt a resolution of the Town of Amherst Authorizing the Adoption of Procedures for Electronic Public Meetings and Public Hearings to Ensure the Continuity of Government During the Covid-19 Pandemic Disaster, as recommended by staff. There being no discussion, the motion 5-0 via the roll call method carried as follows:

D. Dwayne Tuggle		Kenneth G. Bunch	Aye
Rachel A. Carton	Aye	Sarah B. Ogden	Aye
Kenneth S. Watts	Aye	Janice N. Wheaton	Aye

A copy of the Resolution is attached to and made a part of these minutes.

Town Manager Carter gave a brief report on proposed addition to Chapter 4. Art. II. of the Town Code referring to dogs and cats that addresses dogs running at large, a requirement for dogs to be leashed or under the control of a responsible person, and dogs defecating on public or private property.

Mr. Bunch made a motion that was seconded by Mr. Watts to approve the proposed addition to Chapter 4. Art. II of the Town Code referring to dogs and cats allowing the addition of sections for running at large, leash law, unlawful to allow dogs to defecate on public or private property; exception, and violation of article as revised. There being no discussion, the motion 5-0 via the roll call method carried as follows:

D. Dwayne Tuggle		Kenneth G. Bunch	Aye
Rachel A. Carton	Aye	Sarah B. Ogden	Aye
Kenneth S. Watts	Aye	Janice N. Wheaton	Aye

The Ordinance shall become effective June 1, 2020. A copy of the Ordinance is attached to and made a part of these minutes.

Ms. Carton made a motion that was seconded by Mr. Bunch to adopt the proposed Privacy Policy and Terms of Use, as recommended by staff. There being no discussion, the motion 4-1 via the roll call method carried as follows:

D. Dwayne Tuggle		Kenneth G. Bunch	Aye
Rachel A. Carton	Aye	Sarah B. Ogden	Aye
Kenneth S. Watts	Aye	Janice N. Wheaton	Nay

By consensus of Council action on the proposed amendment to the Town’s Comprehensive Plan to change the designated land use for Tax Map parcels 96-4-A and 96-1-1-7, totaling 76+/- acres from Planned Development-Residential to Agricultural to allow a request for a conservation easement by Dave McCormack, Owner, Lazy River LTD, that would, if approved by Town Council, allow land between the developed portion of the Mill Race subdivision and the Amherst Milling Company to be changed from planned development areas to conservation and would allow Mr. McCormick to complete a conservation easement process for the property was deferred to an future meeting with a date uncertain due to the current covid-19 crisis, as recommended by staff.

No Citizen comments were made.

Mrs. Carton made a motion that was seconded by Mr. Watts that Town Council convene in closed session for discussion concerning a prospective business or industry where no previous announcement has been made of

the business’ or industry’s interest in locating its facilities in the community per the exception at §2.2-3711A.5 of the Code of Virginia. The motion 4-1 via the roll call method carried as follows:

D. Dwayne Tuggle		Kenneth G. Bunch	Aye
Rachel A. Carton	Aye	Sarah B. Ogden	Aye
Kenneth S. Watts	Aye	Janice N. Wheaton	Nay

Mayor Tuggle adjourned the open session at 7:30 pm.

The meeting reconvened in closed session. It was noted that a quorum was present as follows:

D. Dwayne Tuggle	Present	Kenneth G. Bunch	Present
Rachel A. Carton	Present	Sarah B. Ogden	Present
Kenneth S. Watts	Present	Janice N. Wheaton	Absent

Mrs. Carton made a motion, seconded by Mr. Watts, that Council adjourn the closed session and reconvene in open session, certifying to the best of each member’s knowledge that (i) only public business matters lawfully exempted from open meeting requirements under Title 2.2, Chapter 37 and §15.2-2907 of the Code of Virginia and (ii) only such public business matters as were identified in the motion by which the closed session was convened were heard, discussed or considered in the session.

The motion 4-0 via the roll call method with Mmes. Carton, Ogden, and Messrs. Watts and Bunch voting “Aye.” Ms. Wheaton was absent.

There being no further business, the meeting adjourned until May 13, 2020, at 7:00 pm on motion by Ms. Ogden seconded by Mr. Bunch.

D. Dwayne Tuggle
Mayor

Attest: _____
Clerk of Council

**A RESOLUTION OF THE TOWN OF AMHERST, VIRGINIA
AUTHORIZING THE ISSUANCE AND SALE OF A
\$3,017,000 GENERAL OBLIGATION SEWER REVENUE BOND, SERIES 2020A AND
A \$397,000 GENERAL OBLIGATION SEWER REVENUE BOND, SERIES 2020B AND
PROVIDING FOR THE FORMS, DETAILS AND PAYMENTS THEREOF**

WHEREAS, the Town of Amherst, Virginia (**the “Town”**) is authorized to acquire, construct, operate and maintain sewer systems in the Town (**the “System”**); and

WHEREAS, the Town is authorized pursuant to the Public Finance Act, Chapter 26 of Title 15.2 of the Code of Virginia of 1950, as amended (**the “Act”**) to borrow money and to issue its general obligation sewer revenue bond to pay all or part of the cost of the System; and

WHEREAS, the Town Council of the Town (**the “Town Council”**) has determined to improve the System located in the Town and that to do so it is necessary to issue its Three Million Seventeen Thousand and 00/100 Dollars (\$3,017,000) General Obligation Sewer Revenue Bond, Series 2020A (**the “Series 2020A RD Bond”**) and its Three Hundred Ninety Seven Thousand and 00/100 Dollars (\$397,000) General Obligation Sewer Revenue Bond, Series 2020B (**the “Series 2020B RD Bond,” together with the Series 2020A RD Bond, the “Series 2020 RD Bonds”**) the proceeds of which, together with other available funds, are estimated to be sufficient to pay the cost of the Project, as defined below, hereinafter authorized; and

WHEREAS, the United States of America, acting through Rural Development and/or Rural Utilities Service (formerly Farmers Home Administration), has offered to purchase the Series 2020 RD Bonds upon certain terms and conditions; and the Town, after consideration of the condition of the municipal bond market, has determined to satisfy such terms and conditions, to authorize and issue its Series 2020 RD Bonds, and to award the sale of the Series 2020 RD Bonds to the United States of America; and

BE IT RESOLVED BY THE TOWN COUNCIL OF THE TOWN OF AMHERST, VIRGINIA, AS FOLLOWS:

ARTICLE I.

DEFINITIONS

Section 1.1 Definitions. Whenever used in this resolution, unless a different meaning clearly appears from the context:

(a) **“Act”** shall mean the Public Finance Act (Chapter 26, Title 15.2, Code of Virginia, 1950, as amended).

(b) **“Additional Bonds”** shall mean any bonds issued pursuant to Article VI and secured on a parity with the Bonds by a pledge of the Net Revenues.

- (c) **“Bondholder”** shall mean the holder or owner of the Series 2020 RD Bonds.
- (d) **“Bond” or “Bonds”** shall mean the Series 2020 RD Bonds and any Additional Bonds.
- (e) **“Certified copy”** shall mean a copy of a resolution or other paper certified by the Town Manager of the Town, Mayor of the Town, Clerk of the Town Council, or by any other authorized Town official.
- (f) **“Closing Date”** shall mean the date on which the Series 2020 RD Bonds are delivered to the United States upon payment of the purchase price therefor.
- (g) **“Consulting Engineer”** shall mean such engineering firm or individual engineer as may be employed by the Town as Consulting Engineer in accordance with Section 9.6.
- (h) **“Costs”** shall mean the cost of improvements; the cost of all lands, properties, rights, easements and franchises acquired and the cost of all conveyances in fee simple of the Town’s title thereto and leased thereof; the cost of preparing the land; the cost of impact fees to host jurisdictions; the cost of all labor, machinery, equipment and furnishings; financing and credit enhancement charges; interest prior to and during construction and for one year after completion of construction; cost of engineering and legal services, plans, specifications, surveys, estimates of costs and revenues; any deposit to any bond interest and principal reserve account; start-up costs and start-up operating capital; other expenses necessary or incident to the determining of the feasibility or practicability of any such acquisition, improvement or construction; administrative expenses and such other expenses as may be necessary or incident to the financing hereby authorized, or to the acquisition, improvement or construction of the Project.
- (i) **“Fiscal Year”** shall mean the twelve-month period beginning on July 1 of one year and ending on June 30 of the following year.
- (j) **“Government”** shall mean the United States of America, its successors and assigns, acting by and through Rural Development and/or Rural Utilities Service, each an agency of the United States Department of Agriculture.
- (k) **“Gross Revenues”** shall mean all revenues, income, and receipts derived or received by the Town from the operation and ownership of the System, including the interest income from the investment or deposit of money in any fund created by this resolution or a supplemental resolution in connection with the System, plus any other money from other sources pledged by the Town to the payment of the Bonds, but “Gross Revenues” shall not mean or include any impact fees or developer fees charged by the Town for the construction of capital improvements or extensions to the System.
- (l) **“Letter of Conditions”** shall mean that certain Letter of Conditions, dated July 23, 2014, as amended March 18, 2020, from the United States to the Town setting forth conditions and requirements for the issuance of the Series 2020 RD Bonds and any supplements thereto.

(m) **“Net Revenues”** shall mean Gross Revenues less Operating Expenses.

(n) **“Operating Expenses”** shall mean the reasonable and necessary expenses of operation, administration, maintenance and repair of the System, excluding any allowance for depreciation, or for reserves and expenditures for capital improvements or extensions to the System.

(o) **“Project”** in the context of this resolution shall mean the renovations and improvements to the Town’s sewer system located in the Town substantially as described on Exhibit A, attached hereto.

(p) **“Series 2020 RD Bonds”** shall mean the Bonds authorized and issued under Section 3.1 hereof.

(q) **“System”** shall mean the Town’s sewer system and all additions, extensions and enlargements thereof and any sewer project or projects that may be duly authorized by the Town and made a part of the System.

(r) **“Town”** shall mean the Town of Amherst, Virginia.

(s) **“Town Council”** shall mean the Town Council of the Town.

(t) **“Town Manager,” “Mayor,” or “Vice Mayor,”** shall mean, respectively, the persons holding such offices of the Town.

Section 1.2 Other Definitions. Words defined elsewhere in this resolution shall have the meanings therein provided.

Section 1.3 Rules of Construction. Unless the context clearly indicates to the contrary, words importing the singular number shall include the plural number and vice versa.

ARTICLE II.

AUTHORIZATION OF PROJECT

Section 2.1 The Project. In order to provide improvements to the sewer facilities serving the Town, the acquisition, construction and equipping of the Project are hereby authorized.

Section 2.2 Modification of Project. The Project authorized hereby may be modified by the Town; provided, however, that any such modification shall first have been approved by the Government and recommended in writing by the Consulting Engineer.

Section 2.3 Project Made Part of System; Pledge of Revenues. All improvements, extensions, additions and replacements constituting the Project financed in part or in whole by the issuance of the Series 2020 RD Bonds shall be a part of the System and all revenues derived from the ownership and operation of the System (the **“System Revenues”**) are pledged to the equal

benefit of the owners of the Series 2020 RD Bonds, but such revenues are not pledged to the benefit of the owners of any other bonds issued by the Town except and to the extent expressly set forth therein and permitted under this Resolution.

ARTICLE III.

AUTHORIZATION, FORM, EXECUTION, DELIVERY AND REGISTRATION OF SERIES 2020 RD BONDS

Section 3.1 Authorization of Series 2020 RD Bonds. There is hereby authorized to be issued (i) a general obligation sewer revenue bond of the Town in the principal amount of Three Million Seventeen Thousand and 00/100 Dollars (\$3,017,000) and (ii) a general obligation sewer revenue bond of the Town in the principal amount of Three Hundred Ninety Seven Thousand and 00/100 Dollars (\$397,000) each to provide funds to finance, in part, the cost of the Project. The Series 2020A RD Bond shall be designated the “Town of Amherst, Virginia, General Obligation Sewer Revenue Bond, Series 2020A (RD).” The Series 2020B RD Bond shall be designated the “Town of Amherst, Virginia, General Obligation Sewer Revenue Bond, Series 2020B (RD).”

Section 3.2 Details of the Series 2020 RD Bonds. The Series 2020A RD Bond shall be issued as one fully registered bond (registered as to principal and interest) without coupons, shall consist of a bond in the denomination of \$3,017,000 numbered R-1, shall be dated as of the Closing Date and shall bear interest on the unpaid principal balance at the rate of 1.375% per year (or such greater or lesser rate as may be agreed to by the Government, subject to a maximum rate of 4.00%). Interest only shall be paid during the first twenty-four (24) months after closing, such interest being payable annually on the first and second anniversary dates of the Closing Date. Thereafter payment for the remaining 456 months of principal and interest shall be made in equally amortized monthly installments which, if the interest rate is 1.375% per annum, such installments shall be in the amount of Eight Thousand Five Hundred Eight and 00/100 Dollars (\$8,508.00) thereafter for a period of thirty-eight (38) years, until paid. If not sooner paid, the final installment shall be due and payable on the fortieth anniversary of the Closing Date of the Series 2020A RD Bond in 2060. Each payment shall be applied first to interest accrued to the payment date and then to principal. If the Closing Date actually occurs on the 29th, 30th or 31st day of a month, then the closing date for purposes of this paragraph shall be deemed to be the 28th day of such month.

The Series 2020B RD Bond shall be issued as one fully registered bond (registered as to principal and interest) without coupons, shall consist of a bond in the denomination of \$397,000 numbered R-1, shall be dated as of the Closing Date and shall bear interest on the unpaid principal balance at the rate of 1.375% per year (or such greater or lesser rate as may be agreed to by the Government, subject to a maximum rate of 4.00%). Interest only shall be paid during the first twenty-four (24) months after closing, such interest being payable annually on the first and second anniversary dates of the Closing Date. Thereafter payment for the remaining 456 months of principal and interest shall be made in equally amortized monthly installments which, if the interest rate is 1.375% per annum, such installments shall be in the amount of One Thousand One Hundred Twenty and 00/100 Dollars (\$1,120.00) thereafter for a period of thirty-eight (38) years, until paid. If not sooner paid, the final installment shall be due and payable on the fortieth anniversary of the

Closing Date of the Series 2020B RD Bond in 2060. Each payment shall be applied first to interest accrued to the payment date and then to principal. If the Closing Date actually occurs on the 29th, 30th or 31st day of a month, then the closing date for purposes of this paragraph shall be deemed to be the 28th day of such month.

Installments of principal may be prepaid at the option of the Town as a whole or in part, without premium (but if in part, in inverse chronological order) on any interest payment date, upon not less than thirty nor more than sixty days' notice forwarded by registered or certified mail to the registered owner of these Bonds at the address shown on the registration books maintained at the office of the Registrar, upon payment of the principal amount of installments to be prepaid and interest accrued to the date fixed for such prepayment, without premium, by check or draft mailed to such owner at such address.

At the request of the Government, the Series 2020A RD Bond may be delivered as fully registered bond in the alternative form contained herein providing for principal advances to be made from time to time by the Government in an aggregate amount not to exceed \$3,017,000 and the Series 2020B RD Bond may be delivered as fully registered bond in the alternative form contained herein providing for principal advances to be made from time to time by the Government in an aggregate amount not to exceed \$397,000. An authorized officer of the Government shall enter the amount and the date of each such principal advance on the Certificate of Principal Advances attached to the respective Series 2020 RD Bonds when the proceeds of such advance are delivered to the Town. Each such principal advance shall bear interest from the date of such advance so entered on such certificate.

Section 3.3 Execution of the Series 2020 RD Bonds. The Series 2020 RD Bonds shall be signed by the manual signature of the Mayor or Vice Mayor of the Town and the Town seal shall be affixed thereto and attested by the Clerk of the Town Council.

Section 3.4 Form of the Series 2020 RD Bonds. The Series 2020 RD Bonds shall be in substantially the following forms:

**UNITED STATES OF AMERICA
COMMONWEALTH OF VIRGINIA
TOWN OF AMHERST**

General Obligation Sewer Revenue Bond, Series 2020A (RD)

Registered Holder: United States of America

Principal Sum: Three Million Seventeen Thousand and 00/100 Dollars

Date: _____, 2020

The Town of Amherst, Virginia (the “Town”), a political subdivision of the Commonwealth of Virginia, for value received, hereby promises to the United States of America, or registered assigns, a sum equal to the amount of principal advances made hereunder but not to exceed the sum of

**THREE MILLION SEVENTEEN THOUSAND AND 00/100 DOLLARS
(\$3,017,000.00)**

and to pay to the registered owner hereof interest on the unpaid principal from the date hereof until payment of the entire principal sum at the rate of 1.375% per year (or such lesser rate as may be agreed to by the Government). Interest only shall be paid during the first twenty four (24) months after closing, such interest being payable annually on the first and second anniversary dates of the Closing Date. Thereafter payment for the remaining 456 months of principal and interest shall be made in equally amortized monthly installments of Eight Thousand Five Hundred Eight and 00/100 Dollars (\$8,508.00) commencing on _____, _____ and thereafter for a period of thirty-eight (38) years, until paid, each payment to be applied first to interest accrued to such payment date and then to principal, and such final installment, if not sooner paid, to be due and payable forty (40) years from the date hereof in 2060. Installments of both principal and interest shall be payable in lawful money of the United States of America by check or draft mailed to the registered owner at its address as it appears on the registration books kept for that purpose at the office of the Town Manager who was appointed as Registrar. This Bond shall be registered as to principal and interest. The final installment of principal shall be payable upon presentation and surrender hereof at the office of the Registrar.

This Bond has been authorized by resolutions adopted by the Town Council on December 11, 2019 and April 8, 2020 (together, “the “Bond Resolution”), and is issued pursuant to the

Public Finance Act (Chapter 26, Title 15.2, Code of Virginia, 1950, as amended) (**the “Act”**) and the Constitution of the Commonwealth of Virginia, to provide funds, along with other monies that may be available, to pay the cost of acquiring, constructing and equipping improvements to the Town’s sewer system (**the “Project”**) located in the Town. Copies of the Bond Resolution are on file at the office of the Town Manager of the Town. Reference is hereby made to the Bond Resolution and any amendments thereto for the provisions, among others, describing the pledge and covenants securing this Bond, the nature and extent of the security therefor, the terms and conditions upon which this Bond is issued, and the rights and obligations of the Town and the rights of the Bondholder(s).

Both principal of and interest on this Bond are payable from ad valorem taxes to be levied without limitation as to rate or amount on all property in the Town subject to taxation and from a pledge of the full faith and credit of the Town and the revenues of the Town’s sewer system (**the “System”**) pledged thereto as herein set forth. Nothing herein or in the Bond Resolution shall be deemed to create or constitute an indebtedness of or a pledge of the faith and credit of the Commonwealth of Virginia or of any county, city, town or other political subdivision of the Commonwealth other than the Town. This Bond also is secured by a pledge of the revenues derived from the ownership and operation of the System.

THIS BOND IS A GENERAL OBLIGATION OF THE TOWN FOR THE PAYMENT OF WHICH THE TOWN’S FULL FAITH AND CREDIT ARE IRREVOCABLY PLEDGED. THE TOWN COUNCIL IS AUTHORIZED AND REQUIRED TO LEVY AND COLLECT ANNUALLY AT THE SAME TIME AND IN THE SAME MANNER AS OTHER TAXES OF THE TOWN ARE ASSESSED, LEVIED AND COLLECTED, A TAX UPON ALL TAXABLE PROPERTY WITHIN THE TOWN, OVER AND ABOVE ALL OTHER TAXES AUTHORIZED OR LIMITED BY LAW AND WITHOUT LIMITATION AS TO RATE OR AMOUNT, SUFFICIENT TO PAY WHEN DUE THE PRINCIPAL OF AND PREMIUM, IF ANY, AND INTEREST ON THE BOND, TO THE EXTENT OTHER FUNDS OF THE TOWN ARE NOT LAWFULLY AVAILABLE AND APPROPRIATED FOR SUCH PURPOSE. THIS BOND ALSO IS PAYABLE FROM CERTAIN REVENUES TO BE DERIVED FROM THE OWNERSHIP OR OPERATION OF THE TOWN’S SYSTEM AS THE SAME MAY FROM TIME TO TIME EXIST, ALL OF WHICH REVENUES HAVE BEEN PLEDGED PURSUANT TO THE BOND RESOLUTION TO SECURE THE PAYMENT THEREOF. NEITHER THE COMMONWEALTH OF VIRGINIA NOR ANY POLITICAL SUBDIVISION THEREOF, OTHER THAN THE TOWN, SHALL BE OBLIGATED TO PAY THE PRINCIPAL OF OR INTEREST ON THE BOND OR OTHER COSTS INCIDENT THERETO EXCEPT FROM THE REVENUES PLEDGED THEREFOR, AND NEITHER THE FAITH AND CREDIT NOR THE TAXING POWER OF THE COMMONWEALTH OF VIRGINIA OR ANY POLITICAL SUBDIVISION THEREOF, OTHER THAN THE TOWN, IS PLEDGED TO THE PAYMENT OF PRINCIPAL OF OR INTEREST ON THE BOND OR OTHER COSTS INCIDENT THERETO.

Installments of principal may be prepaid at the option of the Town as a whole or in part, without premium (but if in part, in inverse chronological order) on any interest payment date, upon not less than thirty nor more than sixty days’ notice forwarded by registered or certified mail to

the registered owner of this Bond at the address shown on the registration books maintained at the office of the Registrar, upon payment of the principal amount of installments to be prepaid and interest accrued to the date fixed for such prepayment, without premium, by check or draft mailed to such owner at such address.

Additional Bonds secured equally and ratably with this Bond may be issued from time to time under the conditions, limitations and restrictions set forth in the Bond Resolution to finance the cost of the completion of the Project, the acquisition or construction of improvements, extensions, additions and replacements to the System, one or more projects duly authorized by the Town and made a part of the System, or to refund bonds of the Town, or for any or all of such purposes.

This Bond is transferable only upon the registration books kept at the office of the Registrar by the registered holder hereof or by his duly authorized attorney, upon surrender of this Bond (together with a written instrument of transfer, satisfactory in form to the Registrar, duly executed by the registered holder or his authorized attorney, which may be in the form endorsed hereon) and subject to the limitations and upon payment of the charges, if any, as provided in the Bond Resolution, and thereupon as provided in the Bond Resolution a new Bond, in the aggregate principal amount and of the same series, interest rate and maturity as the Bond surrendered, shall be issued in exchange therefor. The Town and the Registrar shall deem and treat the person in whose name this Bond is registered as the absolute owner hereof for the purpose of receiving payment of, or on account of, the principal hereof and interest due hereon and for all other purposes whatsoever.

All acts, conditions and things required by the Constitution and statutes of the Commonwealth of Virginia to happen, exist or be performed precedent to, and in the issuance of this Bond have happened, exist and have been performed.

This Bond shall not be valid or obligatory for any purpose unless the Certificate of Authentication hereon has been duly executed by the Registrar and the date of authentication inserted hereon.

IN WITNESS WHEREOF, the Town has caused this Bond to be signed by its Mayor or Vice Mayor, to be countersigned by its Clerk or Deputy Clerk of the Town Council, and this Bond to be dated as of _____, ____.

COUNTERSIGNED:

Clerk, Town Council of the
Town of Amherst, Virginia

Mayor, Town of Amherst, Virginia

CERTIFICATE OF AUTHENTICATION

This Bond is the Series 2020A RD Bond described in the within mentioned Bond Resolution.

Town Manager
Town of Amherst, Virginia

FOR APPROVAL

TRANSFER OF BOND

Transfer of this Bond may be registered by the registered owner or his duly authorized attorney upon presentation hereof to the Registrar who shall make note of such transfer in its books kept by her for that purpose and in the registration blank below:

<u>Date of Registration</u>	<u>Name of Registered Owner</u>	<u>Signature of Registrar</u>
_____	_____	_____
_____	_____	_____
_____	_____	_____

CERTIFICATE OF PRINCIPAL ADVANCES

The amount and date of principal advances not to exceed the face amount hereof shall be entered hereon by an authorized officer of the United States of America, when the proceeds of such principal amounts are delivered to the Town.

<u>Amount</u>	<u>Date</u>	<u>Authorized Signatures</u>
_____	_____	_____
_____	_____	_____
_____	_____	_____
_____	_____	_____
_____	_____	_____

Schedule A

Principal Installments Paid in Advance of Maturity Date

<u>Principal Due Date(s) Inclusive</u>	<u>Principal Payment Amount</u>	<u>Date</u>	<u>Balance</u>	<u>Date Paid</u>	<u>Signature of Registrar</u>
_____	_____	_____	_____	_____	_____
_____	_____	_____	_____	_____	_____
_____	_____	_____	_____	_____	_____
_____	_____	_____	_____	_____	_____

FOR APPROVAL

**UNITED STATES OF AMERICA
COMMONWEALTH OF VIRGINIA
TOWN OF AMHERST**

General Obligation Sewer Revenue Bond, Series 2020B (RD)

Registered Holder: United States of America

Principal Sum: Three Hundred Ninety Seven Thousand and 00/100 Dollars

Date: _____, 2020

The Town of Amherst, Virginia (the “Town”), a political subdivision of the Commonwealth of Virginia, for value received, hereby promises to the United States of America, or registered assigns, a sum equal to the amount of principal advances made hereunder but not to exceed the sum of

**THREE HUNDRED NINETY SEVEN THOUSAND AND 00/100 DOLLARS
(\$397,000.00)**

and to pay to the registered owner hereof interest on the unpaid principal from the date hereof until payment of the entire principal sum at the rate of 1.375% per year (or such lesser rate as may be agreed to by the Government). Interest only shall be paid during the first twenty four (24) months after closing, such interest being payable annually on the first and second anniversary dates of the Closing Date. Thereafter payment for the remaining 456 months of principal and interest shall be made in equally amortized monthly installments of One Thousand One Hundred Twenty and 00/100 Dollars (\$1,120.00)] commencing on _____, _____ and thereafter for a period of thirty-eight (38) years, until paid, each payment to be applied first to interest accrued to such payment date and then to principal, and such final installment, if not sooner paid, to be due and payable forty (40) years from the date hereof in 2060. Installments of both principal and interest shall be payable in lawful money of the United States of America by check or draft mailed to the registered owner at its address as it appears on the registration books kept for that purpose at the office of the Town Manager who was appointed as Registrar. This Bond shall be registered as to principal and interest. The final installment of principal shall be payable upon presentation and surrender hereof at the office of the Registrar.

This Bond has been authorized by resolutions adopted by the Town Council on December 11, 2019 and April 8, 2020 (together, “the “Bond Resolution”), and is issued pursuant to the

Public Finance Act (Chapter 26, Title 15.2, Code of Virginia, 1950, as amended) (**the “Act”**) and the Constitution of the Commonwealth of Virginia, to provide funds, along with other monies that may be available, to pay the cost of acquiring, constructing and equipping improvements to the Town’s sewer system (**the “Project”**) located in the Town. Copies of the Bond Resolution are on file at the office of the Town Manager of the Town. Reference is hereby made to the Bond Resolution and any amendments thereto for the provisions, among others, describing the pledge and covenants securing this Bond, the nature and extent of the security therefor, the terms and conditions upon which this Bond is issued, and the rights and obligations of the Town and the rights of the Bondholder(s).

Both principal of and interest on this Bond are payable from ad valorem taxes to be levied without limitation as to rate or amount on all property in the Town subject to taxation and from a pledge of the full faith and credit of the Town and the revenues of the Town’s sewer system (**the “System”**) pledged thereto as herein set forth. Nothing herein or in the Bond Resolution shall be deemed to create or constitute an indebtedness of or a pledge of the faith and credit of the Commonwealth of Virginia or of any county, city, town or other political subdivision of the Commonwealth other than the Town. This Bond also is secured by a pledge of the revenues derived from the ownership and operation of the System.

THIS BOND IS A GENERAL OBLIGATION OF THE TOWN FOR THE PAYMENT OF WHICH THE TOWN’S FULL FAITH AND CREDIT ARE IRREVOCABLY PLEDGED. THE TOWN COUNCIL IS AUTHORIZED AND REQUIRED TO LEVY AND COLLECT ANNUALLY AT THE SAME TIME AND IN THE SAME MANNER AS OTHER TAXES OF THE TOWN ARE ASSESSED, LEVIED AND COLLECTED, A TAX UPON ALL TAXABLE PROPERTY WITHIN THE TOWN, OVER AND ABOVE ALL OTHER TAXES AUTHORIZED OR LIMITED BY LAW AND WITHOUT LIMITATION AS TO RATE OR AMOUNT, SUFFICIENT TO PAY WHEN DUE THE PRINCIPAL OF AND PREMIUM, IF ANY, AND INTEREST ON THE BOND, TO THE EXTENT OTHER FUNDS OF THE TOWN ARE NOT LAWFULLY AVAILABLE AND APPROPRIATED FOR SUCH PURPOSE. THIS BOND ALSO IS PAYABLE FROM CERTAIN REVENUES TO BE DERIVED FROM THE OWNERSHIP OR OPERATION OF THE TOWN’S SYSTEM AS THE SAME MAY FROM TIME TO TIME EXIST, ALL OF WHICH REVENUES HAVE BEEN PLEDGED PURSUANT TO THE BOND RESOLUTION TO SECURE THE PAYMENT THEREOF. NEITHER THE COMMONWEALTH OF VIRGINIA NOR ANY POLITICAL SUBDIVISION THEREOF, OTHER THAN THE TOWN, SHALL BE OBLIGATED TO PAY THE PRINCIPAL OF OR INTEREST ON THE BOND OR OTHER COSTS INCIDENT THERETO EXCEPT FROM THE REVENUES PLEDGED THEREFOR, AND NEITHER THE FAITH AND CREDIT NOR THE TAXING POWER OF THE COMMONWEALTH OF VIRGINIA OR ANY POLITICAL SUBDIVISION THEREOF, OTHER THAN THE TOWN, IS PLEDGED TO THE PAYMENT OF PRINCIPAL OF OR INTEREST ON THE BOND OR OTHER COSTS INCIDENT THERETO.

Installments of principal may be prepaid at the option of the Town as a whole or in part, without premium (but if in part, in inverse chronological order) on any interest payment date, upon not less than thirty nor more than sixty days’ notice forwarded by registered or certified mail to the registered owner of this Bond at the address shown on the registration books maintained at the

office of the Registrar, upon payment of the principal amount of installments to be prepaid and interest accrued to the date fixed for such prepayment, without premium, by check or draft mailed to such owner at such address.

Additional Bonds secured equally and ratably with this Bond may be issued from time to time under the conditions, limitations and restrictions set forth in the Bond Resolution to finance the cost of the completion of the Project, the acquisition or construction of improvements, extensions, additions and replacements to the System, one or more projects duly authorized by the Town and made a part of the System, or to refund bonds of the Town, or for any or all of such purposes.

This Bond is transferable only upon the registration books kept at the office of the Registrar by the registered holder hereof or by his duly authorized attorney, upon surrender of this Bond (together with a written instrument of transfer, satisfactory in form to the Registrar, duly executed by the registered holder or his authorized attorney, which may be in the form endorsed hereon) and subject to the limitations and upon payment of the charges, if any, as provided in the Bond Resolution, and thereupon as provided in the Bond Resolution a new Bond, in the aggregate principal amount and of the same series, interest rate and maturity as the Bond surrendered, shall be issued in exchange therefor. The Town and the Registrar shall deem and treat the person in whose name this Bond is registered as the absolute owner hereof for the purpose of receiving payment of, or on account of, the principal hereof and interest due hereon and for all other purposes whatsoever.

All acts, conditions and things required by the Constitution and statutes of the Commonwealth of Virginia to happen, exist or be performed precedent to, and in the issuance of this Bond have happened, exist and have been performed.

This Bond shall not be valid or obligatory for any purpose unless the Certificate of Authentication hereon has been duly executed by the Registrar and the date of authentication inserted hereon.

IN WITNESS WHEREOF, the Town has caused this Bond to be signed by its Mayor or Vice Mayor, to be countersigned by its Clerk or Deputy Clerk of the Town Council, and this Bond to be dated as of _____, ____.

COUNTERSIGNED:

Clerk, Town Council of the
Town of Amherst, Virginia

Mayor, Town of Amherst, Virginia

CERTIFICATE OF AUTHENTICATION

This Bond is the Series 2020B RD Bond described in the within mentioned Bond Resolution.

Town Manager
Town of Amherst, Virginia

FOR APPROVAL

TRANSFER OF BOND

Transfer of this Bond may be registered by the registered owner or his duly authorized attorney upon presentation hereof to the Registrar who shall make note of such transfer in its books kept by her for that purpose and in the registration blank below:

<u>Date of Registration</u>	<u>Name of Registered Owner</u>	<u>Signature of Registrar</u>
_____	_____	_____
_____	_____	_____
_____	_____	_____

CERTIFICATE OF PRINCIPAL ADVANCES

The amount and date of principal advances not to exceed the face amount hereof shall be entered hereon by an authorized officer of the United States of America, when the proceeds of such principal amounts are delivered to the Town.

<u>Amount</u>	<u>Date</u>	<u>Authorized Signatures</u>
_____	_____	_____
_____	_____	_____
_____	_____	_____
_____	_____	_____
_____	_____	_____

Schedule A

Principal Installments Paid in Advance of Maturity Date

<u>Principal Due Date(s) Inclusive</u>	<u>Principal Payment Amount</u>	<u>Date</u>	<u>Balance</u>	<u>Date Paid</u>	<u>Signature of Registrar</u>
_____	_____	_____	_____	_____	_____
_____	_____	_____	_____	_____	_____
_____	_____	_____	_____	_____	_____
_____	_____	_____	_____	_____	_____

Section 3.5 Registration and Exchange of Bonds. The Town Manager is hereby appointed Registrar. Transfer of the Bonds shall be registered upon books maintained for that purpose at the office of the Registrar. Prior to due presentment for registration of transfer, the Registrar shall treat the registered owner as the person exclusively entitled to payment of principal and interest and the exercise of all other rights and powers of the owner. The Bonds initially shall be registered as to principal and interest in the name of the United States of America, with an address of Finance Office, USDA/Rural Development, 1520 Market Street, St. Louis, Missouri 63103-2696.

Section 3.6 Delivery of the Series 2020 RD Bonds. The Mayor or Vice Mayor and Town Manager are hereby authorized and directed to have the Bonds prepared and executed in accordance with the terms thereof and to deliver the Series 2020 RD Bonds to the United States upon payment therefor. The Mayor or Vice Mayor and Town Manager are further authorized and directed to agree to and comply with, on behalf of the Town, any and all further conditions and requirements of the United States in connection with its purchase of the Bonds.

Section 3.7 Replacement of Mutilated, Lost or Destroyed Bonds. Should the Bonds become mutilated or be lost or destroyed, the Town shall cause to be executed and delivered a new Bond of like date, number, series and tenor in exchange and substitution for, and upon cancellation of, such mutilated Bond or in lieu of and in substitution for such lost or destroyed Bond. Such new Bond shall be executed and delivered only when the owner has paid all reasonable expenses and charges in connection therewith and, in the case of a lost or destroyed Bond, has filed with the Town and the Registrar evidence satisfactory to them that such Bond was lost or destroyed and that he was the owner thereof and the owner has furnished to the Registrar indemnity satisfactory to him; provided, however, that no surety on such indemnity shall be required from the Government.

ARTICLE IV.

PREPAYMENT OF BONDS

Section 4.1 Prepayment Dates and Prices. Installments of principal at the option of the Town, may be prepaid as a whole, or in part, without premium (but if in part, in inverse chronological order) on any interest payment date, upon payment of the principal amount of the installments to be prepaid and interest accrued to the date fixed for such prepayment, without premium.

Section 4.2 Manner of Effecting Prepayment. Prepayment of the Bonds shall be effected in the following manner:

(a) The Town shall approve prepayment of installments which are by their terms subject to prepayment and fixing a date for such prepayment.

(b) Not less than thirty nor more than sixty days prior to such prepayment date, the Town shall cause a notice of such prepayment to be sent by registered or certified mail to the registered owner of the Bonds to be prepaid at its address appearing on the registration books of the Town. The notice of prepayment shall state the date fixed for prepayment, the place at which payment will be made and, if less than all of the Bonds or less than the entire principal of any single fully registered Bond shall be called for prepayment, the numbers of Bonds or installments of any single Bond to be prepaid.

(c) On or prior to the date fixed for prepayment the Registrar shall make available at his office the amount to be prepaid and accrued interest.

Section 4.3 Cancellation of Prepaid Bonds. The Bonds so prepaid in full shall be cancelled upon surrender.

ARTICLE V.

REVENUES AND FUNDS

Section 5.1 Revenue Covenant. The Town covenants that so long as the Series 2020 RD Bonds are outstanding it will fix, charge and collect such rates, fees and other charges for the use of and for the services furnished by the System and will from time to time revise such rates, fees and other charges so as to produce sufficient revenues in each fiscal year to equal an amount required to pay (i) the Operating Expenses which shall accrue and become payable during the then current fiscal year, and (ii) the amounts required by Section 3.2 to be paid during the then current fiscal year on debt service for the Bonds.

Section 5.2 Free Service; Enforcement of Charges.

(a) So long as the Series 2020 RD Bonds are outstanding the Town shall not permit connections to or use of the System or provide any services of the System without making a charge

therefor; provided, however, that the Town may supply water service to facilities on public property without making a charge.

(b) If any rates, fees or charges for the use of and for the services furnished by the System shall not be paid within 60 days after the same shall become due and payable, or within such shorter time as may be determined by the Town, the Town may at the expiration of such period disconnect the premises from the System or otherwise suspend service to such premises until such delinquent rates, fees or charges and any interest, penalties or charges for reconnection shall have been paid in full, unless the State Health Commissioner shall have found and shall certify to the Town that suspending such services will endanger the health of the persons occupying such premises or the health of others.

(c) The Town shall take all such action as may be necessary to perfect liens upon real estate for the amount of any unpaid rates, fees or charges described in paragraph (b) above or any unpaid connection charges or other charges so that such liens will be binding upon subsequent bona fide purchasers for valuable consideration without actual notice thereof.

Section 5.3 Pledge of Revenues. All revenues derived by the Town from the use of and services furnished by the System are hereby pledged equally and ratably to the payment of the principal of and interest on the Bonds, subject only to the right to make application thereof to other purposes as provided herein.

ARTICLE VI.

ADDITIONAL BONDS

Section 6.1. Issuance of Additional Bonds. The Town may Issue Additional Bonds to finance the cost of completing the Project or the acquisition or construction of improvements, extensions, additions and replacements to the System or to refund any Bonds. Additional Bonds shall be in such form, shall be dated such date shall mature in such installments of principal and interest, shall bear interest at such rate or rates, shall be in such denomination or denominations and may contain such provisions for prepayment prior to their respective maturities, all as provided by the Town Council by resolution adopted prior to their Issuance. Additional Bonds shall contain an appropriate series designation.

Section 6.2. Conditions of Issuance. The Town shall not issue any Additional Bonds unless there shall have been filed with the Town and, if the Government is the Owner of either the Series 2020 RD Bonds or any Additional Bonds, with the Government, the following:

(a) a certified copy of a resolution of the Town Council in form complying with the foregoing provisions specifying or providing for all the terms of the Additional Bonds and, if applicable, stating the cost of the acquisition or construction of any improvements, extensions, additions and replacements to the System to be acquired or constructed and finding and ordering that such improvements, extensions, additions and replacements shall be a part of the System;

(b) a certified copy of a resolution of the Town Council specifying or providing for the interest rate or rates and directing the delivery of such Additional Bonds to the purchaser or purchasers upon payment of the purchase price set forth therein;

(c) if the Additional Bonds are to be issued to complete the Project, a certificate of the Consulting Engineer to that effect;

(d) if the Additional Bonds are to be issued for any purpose other than the refunding of Bonds or the completion of the Project, either (i) a certificate of an independent certified public accountant or engineering firm stating that the amount of the Net Revenues for the fiscal year preceding the year in which the proposed Additional Bonds are to be issued was not less than one hundred percent (100%) of the average annual principal and interest requirements for the Bonds then outstanding and the Additional Bonds to be issued, or (ii) the written consent of the holders of three-fourths in aggregate principal amount of the Bonds outstanding;

(e) a certificate of the Town, signed by the Mayor or Vice Mayor of the Town, that the Town is in compliance with all covenants and undertakings in connection with this resolution and any supplemental resolution authorizing Additional Bonds which remain outstanding; and

(f) the written opinion or opinions of counsel for the Town stating that the issuance of the Additional Bonds has been duly authorized and that all conditions precedent to their delivery have been fulfilled.

ARTICLE VII.

DISBURSEMENT OF BOND PROCEEDS

Section 7.1 Disbursement of Bond Proceeds. Principal advances shall be made by the Government, in an aggregate amount not to exceed \$3,017,000 under the Series 2020A RD Bond and \$397,000 under the Series 2020B RD Bond, upon application by the Town and compliance with all Government requirements. An authorized officer of Government shall enter the amount and the date of each such principal advance on the Certificate of Principal Advances (**the “Certificate”**), attached to the respective Series 2020 RD Bond when the proceeds of such advances are delivered to the Town. Each principal advance shall bear interest from the date of the advance entered on the Certificate.

ARTICLE VIII.

SECURITY FOR DEPOSITS AND INVESTMENTS OF FUNDS

Section 8.1 Security for Deposits. All moneys on deposit with any bank or trust company shall be secured for the benefit of the Town and the Bondholders in the manner required by Chapters 44, 45, and 46 of Title 2.2, Code of Virginia of 1950, as amended).

ARTICLE IX.

PARTICULAR COVENANTS

Section 9.1 General. The Town hereby particularly covenants and agrees with the owner of the Bond and makes provisions which shall become a part of its contract with such Bondholder as set forth in the following sections of this Article.

Section 9.2 Payment of Bonds. The Town shall pay promptly, as provided herein, the principal of and interest on the Bonds issued pursuant to this resolution, but such principal and interest shall be payable from ad valorem taxes to be levied without limitation as to rate or amount on all property in the Town subject to taxation, from the revenues of the System pledged herein, and the full faith and credit of the Town is pledged to the payment of the Bonds. Nothing in the Bonds or in this resolution shall be deemed to create or constitute an indebtedness of or a pledge of the faith and credit of the Commonwealth of Virginia or of any county, city, town or other political subdivision of the Commonwealth, other than the Town.

Section 9.3 Construction of System. The Town shall obtain all approvals, permits and consents required by law as a condition precedent to the construction, development, operation and improvement of all parts of the System and shall complete the construction of the Project in a sound and economical manner and in conformity with all applicable requirements of governmental authorities and do all acts and things necessary and reasonable so that it may begin to collect revenues from the Project at the earliest practicable time.

Section 9.4 Operation and Maintenance. The Town shall establish and enforce reasonable rules and regulations governing the use and services of the System, maintain and operate the System in an efficient and economical manner, maintain the same in good repair and sound operating condition and make all necessary repairs, replacements and renewals. All compensation, salaries, fees and wages paid by it in connection with the operation, maintenance and repair of the System shall be reasonable. The Town shall observe and perform all the terms and conditions contained in the Act and comply with all valid acts, rules regulations, orders and directions of any legislative, executive, administrative or judicial body applicable to the System or the Town.

Section 9.5 Competition. The Town shall not operate or assent to the operation of any sewer service in competition with the System.

Section 9.6 Consulting Engineer. The Town shall employ as necessary as Consulting Engineer an engineering firm or individual engineer of recognized standing and experience in the field of sewer system engineering, whose duties shall include supervision of the construction of improvements to the System and advice as to proper operation, maintenance and repair of the System.

Section 9.7 Sale or Encumbrance. Neither the System nor any integral part thereof shall be sold, encumbered or otherwise disposed of; provided, however, that the Town may grant

easements, licenses or permits across, over or under parts of the System for streets, roads and utilities as will not adversely affect the use of the System and provided, further, that the Town may sell or otherwise dispose of any property constituting a part of the System that is no longer needed or useful for such purpose that may be used by the Town for any lawful purpose related to the System. Notwithstanding the foregoing, for so long as the Series 2020 RD Bonds are owned by the United States of America any sale, encumbrances or other disposition of the System or any part thereof, not expressly permitted or contemplated hereby, must first be consented to in writing by a representative of the Government.

Section 9.8 Creation of Liens. The Town shall not create or suffer to be created any lien or charge upon the System or any part thereof, except as provided herein. The Town shall pay or cause to be discharged, or shall make adequate provision to satisfy and discharge, all lawful claims and demands for labor, materials or supplies within sixty days after the same shall accrue and all governmental charges when the same become due, which, if unpaid, might by law become a lien upon the System or any part thereof; provided, however, that nothing contained in this section shall require the Town to pay or cause to be discharged or make provision for any such lien or charge so long as the validity thereof shall be contested in good faith and by appropriate legal proceedings.

Section 9.9 Title to Lands. The Town shall make no contract requiring payment for labor or to contractors, builders or materialmen on account of the construction or reconstruction of any part of the System unless such part is located on lands to which title in fee simple or over which perpetual easement, in either case sufficient for the purposes of the System, is owned or can be acquired by the Town, or unless such part is lawfully located in public street or highway or is a main, conduit, pipeline, main connection or outfall located on land in which a right or interest less than a fee simple or perpetual easement has been acquired and such lesser right or interest has been approved by written opinion of counsel for the Town as sufficient for the purposes of the Town.

Section 9.10 Insurance. The Town shall maintain insurance as follows:

(a) The Town shall keep insured all above-ground structures forming a part of the System, as well as all other insurable portions of the System of a type that are customarily insured by other publicly owned sewer systems, against loss by fire, including extended coverage, tornado and windstorm, to such extent as may be necessary to provide for a full recovery whenever an insured loss does not exceed eighty percent (80%) of the full insurable value of the property damaged. All proceeds of such insurance shall be applied promptly to the repair or replacement of the property damaged or destroyed.

(b) The Town shall carry public liability insurance relating to the operation of the System with limits of not less than \$1,000,000 to protect the Town from claims for bodily injury, or damage to property of others which may arise from the ownership or operation of the System.

(c) The Town shall carry workers' compensation insurance in such amounts and upon such terms so that it will not be considered a self-insurer of its liability to its employees under the Virginia Workers' Compensation Act.

(d) All policies of insurance, accompanied by receipts showing payment of premiums in full, shall be deposited in the office of the Town Manager of the Town.

(e) The Town shall obtain surety bonds on all of its officers and employees who may handle funds pertaining to the System, such bonds to be in such amounts as are customarily carried by public bodies owning and operating similar systems.

All such insurance shall be taken out and maintained with generally recognized insurance companies and may be written with deductible amounts comparable to those on similar policies carried by other public bodies owning and operating similar systems.

Section 9.11 Records and Reports. The Town shall keep proper books of record and accounts, separate from any of its other records and accounts, showing complete and correct entries of all transactions relating to the System, and any Bondholder shall have the right at all reasonable times to inspect the System and all records, accounts and data relating thereto. The Town shall also cause an annual audit of its books and accounts to be made by an independent certified public accountant at the end of each fiscal year. No later than two hundred and forty days after the end of each fiscal year, copies of the audit report, certified by such accountant, reflecting in reasonable detail the financial condition and record of operation of the System, including specifically the rates charged, the number of connections served, and the tap fees collected for new connections, shall be filed in the office of the Town Manager of the Town and shall be mailed to any Bondholder who may have requested the same in writing.

Section 9.12 Refinancing. The Town shall refinance the unpaid principal balance of the Series 2020 RD Bonds upon the request of the United States of America if at any time it shall appear to the Government that the Town is able to do so with funds obtained from responsible private sources at reasonable rates and terms for loans for similar purposes and periods of time.

Section 9.13 Covenant as to Other Bonds. The Town covenants that as of the date of this resolution there are no outstanding bonds, notes or other revenue bond obligations concerning the System other than the Series 2020 RD Bonds.

ARTICLE X.

AMENDMENTS

Section 10.1 Amendments Without Consent: The Town shall have the right, from time to time, without the consent of the Bondholder to adopt resolutions supplemental hereto, not inconsistent with the terms and provisions hereof:

(a) to cure any ambiguity or formal defect or omission or to correct any inconsistent provisions in this resolution or in any supplemental resolution;

(b) to grant to or confer upon the Bondholder any additional lawful right, remedy, power, authority or security;

(c) to add conditions, limitations, and restrictions on the issuance of Additional Bonds;
and

(d) to add other covenants and agreements to be observed by the Town or to surrender any right or power herein reserved to or conferred upon the Town.

No such supplemental resolution shall become effective until certified copies have been filed in the office of the Town Manager of the Town.

Section 10.2 Amendments Requiring Consent. The owners of not less than sixty-five percent in principal amount of the Bonds then outstanding shall have the right, from time to time, but only pursuant to this section, to consent to and approve the adoption of such resolution or resolutions supplemental hereto as shall be deemed necessary or desirable by the Town for the purpose of modifying, altering, amending, adding to or rescinding, in any particular, any of the terms or provisions contained in this resolution or in any supplemental resolution; provided, however, that nothing herein contained shall permit or be construed as permitting (a) an extension of the maturity of the principal of or the interest on any Bonds or the prepayment premium, if any, or the rate of interest thereon, or (b) the creation of a lien upon or a pledge of revenues other than the lien and pledge created by this resolution or otherwise permitted hereby, or (c) a preference or priority of any Bond or Bonds over any other Bond or Bonds, or (d) a reduction in the principal amount of Bonds required for consent to such supplemental resolution. Nothing herein contained, however, shall be construed as making necessary the approval by Bondholders of the adoption of any supplemental resolution authorized by Section 10.1.

Section 10.3 Adoption and Consent to Amendment. Upon the adoption of any supplemental resolution for any of the purposes of Section 10.2, a certified copy thereof shall be filed in the office of the Town Manager of the Town for inspection by any Bondholder. The Town Manager shall cause a copy of such supplemental resolution or a summary thereof, together with a request to the Bondholders for their consent thereto, to be sent by registered or certified mail to the registered owner of each Bond at his address as it appears on the registration books of the Town; provided, however, that failure to mail any such notice shall not affect the validity of such supplemental resolution when consented to and approved as provided in this section. If, within sixty days or such longer period as shall be prescribed by the Town following the giving of such notice, the Town shall file in its office, and in the office of the Government, an instrument or instruments in writing purporting to be executed by the holders of not less than sixty-five percent in principal amount of the Bonds then outstanding, which shall refer to the supplemental resolution and shall specifically consent to and approve the adoption thereof, together with a certified copy of such supplemental resolution and the written opinion of counsel for the Town stating that such resolution has been duly adopted, is authorized or permitted by this resolution and is valid and legally binding upon the Town and enforceable in accordance with its terms, such supplemental resolution shall thereupon be effective as the owners of all the Bonds then outstanding, whether or not such owners shall have consented thereto.

Section 10.4 Amendment by Unanimous Consent. Notwithstanding any other provisions herein, the Town may amend any term or provision of this resolution or any supplemental

resolution upon adoption of a supplemental resolution and the filing of certified copies of such supplemental resolution, together with the written consent thereto of the owners of the Bonds then outstanding, as provided in Section 10.3.

Section 10.5 Effect of Amendments. This resolution shall be deemed modified and amended, and the respective rights, duties and obligations hereunder of the Town and any owner of the Bonds then outstanding shall be determined and enforced under the provisions of this resolution, as so modified and amended, upon the adoption of any amendment as provided in this Article.

ARTICLE XI.

DISCHARGE UPON PAYMENT

Section 11.1 Discharge Upon Payment of Bonds. If any Bonds shall have become due and payable at maturity or shall have been duly called for prepayment and the full amount of the principal, interest and premium, if any, so due and payable upon the Bonds then outstanding shall have been paid at the time and in the manner provided therein and in this resolution, then the right, title and interest of the Bondholder in the revenues and the other moneys, funds and securities pledged under this resolution and all covenants, agreements and other obligations of the Town to the Bondholder under this resolution shall cease, terminate and be void, and the Town shall be discharged from its obligations hereunder. In such event all moneys and securities not required for the payment of the principal, interest and prepayment premium, if any on the Bonds, may be used by the Town for any lawful purpose.

ARTICLE XII.

MISCELLANEOUS

Section 12.1 Contract with Bondholders: The provisions of this resolution shall constitute a contract between the Town and the Bondholder for so long as any Bonds or interest thereon is outstanding.

Section 12.2 Town Officers and Agents. The officers and agents of the Town shall do and are authorized to perform all acts and things required of them by this resolution, the Bonds and the Act for the complete and punctual performance of all the terms, covenants and agreements therein, and to do all acts and things and execute all documents and certificates required by the Government in connection with the issuance of the Bonds (including but not limited to an initial operating budget, a request for obligation of funds, an equal opportunity agreement, an assurance agreement, an applicant certification concerning collection policies for consumer or commercial debts, a certification regarding debarment, suspension and other responsibility matters, a certification regarding drug-free workplace requirements, and a certification for contracts, grants, and loans regarding lobbying, all in standard form acceptable to the Government), and such actions of the officers and agents of the Town are hereby approved and ratified.

Section 12.3 Successors and Assigns. All the covenants, stipulations, promises and agreements of the Town contained in this resolution shall bind and inure to the benefit of its successors and assigns, whether so expressed or not.

Section 12.4 Limitation of Rights. Nothing expressed or mentioned in or to be implied from this resolution or the Bond is intended or shall be construed to give to any person or company other than the parties hereto and the owner of the Bonds any legal or equitable rights, remedy or claim under or in respect to this resolution or any covenants, conditions and agreements herein contained; this resolution and all of the covenants, conditions and agreements hereof being intended to be and being for the sole and exclusive benefit of the parties hereto and the owners of the Bonds as herein provided.

Section 12.5 Limitation of Liability of the Town, etc. No covenant, condition or agreement contained herein shall be deemed to be a covenant, agreement or obligation of a present or future member of the Town Council, officer, employee or agent of the Town in his individual capacity, and neither the members of the Town Council nor any officer thereof executing the Bond shall be liable personally on the Bonds or be subject to any personal liability or accountability by reason of the issuance thereof. No member of the Town Council, officer, employee or agent of the Town shall incur any personal liability in acting or proceeding, or in not acting or not proceeding, in good faith, reasonably and in accordance with the terms of this resolution or the Act.

Section 12.1 Notice. Any provision in this resolution for the giving, filing, mailing or delivery of notice or other papers shall be deemed fully complied with if, and when, such notice or other papers are sent by registered or certified mail, return receipt requested, to the Town, addressed to Town Manager, Town of Amherst, 174 S. Main Street, P.O. Box 280, Amherst, VA 24521.

Section 12.2 Headings. Any headings in this resolution are solely for convenience of reference and shall not constitute a part of the resolution nor shall they affect its meaning, construction or effect.

Section 12.3 Conditions Precedent: Upon the issuance of the Bonds all acts, conditions, and things required by the Constitution and statutes of the Commonwealth of Virginia or this resolution to have happened, exist and to have been performed precedent to or in the issuance of the Bonds shall have happened, exist and have been performed.

Section 12.4 [RESERVED].

Section 12.5 Series Designation. In the event the Series 2020 RD Bonds are not issued during calendar year 2020, the Mayor or Vice Mayor and Town Manager of the Town are hereby authorized and directed to change the series designation to such other year as may be appropriate at the time of their issuance. Thereafter all references in this resolution to the Series 2020A RD Bond shall be deemed to refer to the \$3,017,000 General Obligation Sewer Revenue Bond and the

Series 2020B RD Bond shall be deemed to refer to the \$397,000 General Obligation Sewer Revenue Bond each issued pursuant to Article III under the new series designation.

Section 12.6 Government Resolution. The Government Loan Form Resolution attached hereto as Exhibit B is hereby adopted and incorporated herein and to the extent of any inconsistency with this resolution and the Government Resolution, the Government Resolution shall control.

Section 12.7 Severability. The provisions of this resolution are hereby declared to be severable. If any court of competent jurisdiction shall hold any provision of this resolution to be invalid and unenforceable, such holding shall not affect any other provision hereof.

Section 12.8 Approval of Sewer System Grant Agreement. The Town hereby accepts a grant or grants from the Government in accordance with the Sewer System Grant Agreement or Agreements from the Government, previously approved and obligated, in an amount not to exceed \$1,076,000 and a subsequent grant in the amount of \$938,000 for a total amount not to exceed of \$2,014,000, presented at this meeting, which Sewer System Grant Agreement or Agreements are hereby approved in substantially the forms presented to this meeting with such completions, omissions, insertions and changes as may be approved by the officer executing it, his execution to constitute conclusive evidence of his approval of any such completions, omissions, insertions and changes. The Mayor, Vice Mayor and Town Manager of the Town, and each of them, are authorized to execute the Sewer System Grant Agreement or Agreements in accordance with the foregoing. The Mayor, Vice Mayor and Town Manager of the Town, and all other officers, employees and agents of the Town are hereby authorized and directed to take any and all such further action as shall be deemed necessary or desirable to close on the grant in accordance with the approved Sewer System Grant Agreement, and all such action is hereby approved and ratified.

Section 12.9 Effective Date. This resolution shall take effect immediately. A certified copy of this Bond Resolution shall be filed by the Clerk of the Town Council with the Clerk of the Circuit Court of the County of Amherst, Virginia. The filing of this Bond Resolution with the Clerk of the Circuit Court of the County of Amherst, Virginia shall be deemed to be the filing of a resolution authorizing the issuance of bonds with such Court for all purposes of the Act.

[Remainder of this Page Intentionally Left Blank]

The Members of the Town Council voted as follows:

Ayes

Nays

Absent

Abstentions

Adopted this 8th day of April, 2020.

The undersigned Clerk of the Town Council of the Town of Amherst, Virginia hereby certifies that the foregoing constitutes a true and correct extract from the minutes of a meeting of the Town Council held on April 8, 2020, and of the whole thereof so far as applicable to the matters referred to in such extract. I hereby further certify that such meeting was a regularly called meeting and that, during the consideration of the foregoing resolution, a quorum was present and action was taken in an open meeting.

Dated this __ day of _____, 2020.

Clerk, Town Council of the
Town of Amherst, Virginia

EXHIBIT A

PROJECT DESCRIPTION

Improvements to the Town's sewer system.

FOR APPROVAL

EXHIBIT B

UNITED STATES OF AMERICA LOAN FORM RESOLUTION

FOR APPROVAL

LOAN RESOLUTION
(Public Bodies)

A RESOLUTION OF THE Town Council

OF THE Town of Amherst, Virginia

AUTHORIZING AND PROVIDING FOR THE INCURRENCE OF INDEBTEDNESS FOR THE PURPOSE OF PROVIDING A PORTION OF THE COST OF ACQUIRING, CONSTRUCTING, ENLARGING, IMPROVING, AND/OR EXTENDING ITS sewer systems in the Town

FACILITY TO SERVE AN AREA LAWFULLY WITHIN ITS JURISDICTION TO SERVE.

WHEREAS, it is necessary for the Town of Amherst, Virginia

(Public Body)

(herein after called Association) to raise a portion of the cost of such undertaking by issuance of its bonds in the principal amount of \$3,017,000 (Series 2020A RD Bond) and \$397,000 (Series 2020B RD Bond)

pursuant to the provisions of the Public Finance Act, Chapter 26 of Title 15.2 of the Code of Virginia, as amended; and

WHEREAS, the Association intends to obtain assistance from the United States Department of Agriculture, (herein called the Government) acting under the provisions of the Consolidated Farm and Rural Development Act (7 U.S.C. 1921 et seq.) in the planning, financing, and supervision of such undertaking and the purchasing of bonds lawfully issued, in the event that no other acceptable purchaser for such bonds is found by the Association:

NOW THEREFORE, in consideration of the premises the Association hereby resolves:

1. To have prepared on its behalf and to adopt an ordinance or resolution for the issuance of its bonds containing such items and in such forms as are required by State statutes and as are agreeable and acceptable to the Government.
2. To refinance the unpaid balance, in whole or in part, of its bonds upon the request of the Government if at any time it shall appear to the Government that the Association is able to refinance its bonds by obtaining a loan for such purposes from responsible cooperative or private sources at reasonable rates and terms for loans for similar purposes and periods of time as required by section 333(c) of said Consolidated Farm and Rural Development Act (7 U.S.C. 1983(c)).
3. To provide for, execute, and comply with Form RD 400-4, "Assurance Agreement," and Form RD 400-1, "Equal Opportunity Agreement," including an "Equal Opportunity Clause," which clause is to be incorporated in, or attached as a rider to, each construction contract and subcontract involving in excess of \$10,000.
4. To indemnify the Government for any payments made or losses suffered by the Government on behalf of the Association. Such indemnification shall be payable from the same source of funds pledged to pay the bonds or any other legal ly permissible source.
5. That upon default in the payments of any principal and accrued interest on the bonds or in the performance of any covenant or agreement contained herein or in the instruments incident to making or insuring the loan, the Government at its option may (a) declare the entire principal amount then outstanding and accrued interest immediately due and payable, (b) for the account of the Association (payable from the source of funds pledged to pay the bonds or any other legally permissible source), incur and pay reasonable expenses for repair, maintenance, and operation of the facility and such other reasonable expenses as may be necessary to cure the cause of default, and/or (c) take possession of the facility, repair, maintain, and operate or rent it. Default under the provisions of this resolution or any instrument incident to the making or insuring of the loan may be construed by the Government to constitute default under any other instrument held by the Government and executed or assumed by the Association, and default under any such instrument may be construed by the Government to constitute default hereunder.
6. Not to sell, transfer, lease, or otherwise encumber the facility or any portion thereof, or interest therein, or permit others to do so, without the prior written consent of the Government.
7. Not to defease the bonds, or to borrow money, enter into any contractor agreement, or otherwise incur any liabilities for any purpose in connection with the facility (exclusive of normal maintenance) without the prior written consent of the Government if such undertaking would involve the source of funds pledged to pay the bonds.
8. To place the proceeds of the bonds on deposit in an account and in a manner approved by the Government. Funds may be deposited in institutions insured by the State or Federal Government or invested in readily marketable securities backed by the full faith and credit of the United States. Any income from these accounts will be considered as revenues of the system.
9. To comply with all applicable State and Federal laws and regulations and to continually operate and maintain the facility in good condition.
10. To provide for the receipt of adequate revenues to meet the requirements of debt service, operation and maintenance, and the establishment of adequate reserves. Revenue accumulated over and above that needed to pay operating and maintenance, debt service and reserves may only be retained or used to make prepayments on the loan. Revenue cannot be used to pay any expenses which are not directly incurred for the facility financed by USDA. No free service or use of the facility will be permitted.

According to the Paperwork Reduction Act of 1995, an agency may not conduct or sponsor, and a person is not required to respond to, a collection of information unless it displays a valid OMB control number. The valid OMB control number for this information collection is 0572-0121. The time required to complete this information collection is estimated to average 1 hour per response, including the time for reviewing instructions, searching existing data sources, gathering and maintaining the data needed, and completing and reviewing the collection of information.

11. To acquire and maintain such insurance and fidelity bond coverage as may be required by the Government.
12. To establish and maintain such books and records relating to the operation of the facility and its financial affairs and to provide for required audit thereof as required by the Government, to provide the Government a copy of each such audit without its request, and to forward to the Government such additional information and reports as it may from time to time require.
13. To provide the Government at all reasonable times access to all books and records relating to the facility and access to the property of the system so that the Government may ascertain that the Association is complying with the provisions hereof and of the instruments incident to the making or insuring of the loan.
14. That if the Government requires that a reserve account be established, disbursements from that account(s) may be used when necessary for payments due on the bond if sufficient funds are not otherwise available and prior approval of the Government is obtained. Also, with the prior written approval of the Government, funds may be withdrawn and used for such things as emergency maintenance, extensions to facilities and replacement of short lived assets.
15. To provide adequate service to all persons within the service area who can feasibly and legally be served and to obtain USDA's concurrence prior to refusing new or adequate services to such persons. Upon failure to provide services which are feasible and legal, such person shall have a direct right of action against the Association or public body.
16. To comply with the measures identified in the Government's environmental impact analysis for this facility for the purpose of avoiding or reducing the adverse environmental impacts of the facility's construction or operation.
17. To accept a grant in an amount not to exceed \$ 1,076,000 and a subsequent grant of \$938,000 for a total of \$2,014,000

under the terms offered by the Government; that the Town Manager

and Mayor of the Association are hereby authorized and empowered to take all action necessary or appropriate in the execution of all written instruments as may be required in regard to or as evidence of such grant; and to operate the facility under the terms offered in said grant agreement(s).

The provisions hereof and the provisions of all instruments incident to the making or the insuring of the loan, unless otherwise specifically provided by the terms of such instrument, shall be binding upon the Association as long as the bonds are held or insured by the Government or assignee. The provisions of sections 6 through 17 hereof may be provided for in more specific detail in the bond resolution or ordinance; to the extent that the provisions contained in such bond resolution or ordinance should be found to be inconsistent with the provisions hereof, these provisions shall be construed as controlling between the Association and the Government or assignee.

The vote was: Yeas _____ Nays _____ Absent _____

IN WITNESS WHEREOF, the Town Council of the Town of Amherst, Virginia

has duly adopted this resolution and caused it to be executed by the officers below in duplicate on this 8th, April day of 2020

TOWN OF AMHERST, VIRGINIA

(SEAL) By _____

Attest: Title Mayor

Title Clerk of Council

CERTIFICATION TO BE EXECUTED AT LOAN CLOSING

I, the undersigned, as _____ of the _____
hereby certify that the _____ of such Association is composed of
_____ members, of whom , _____ constituting a quorum, were present at a meeting thereof duly called and
held on the _____ day of _____ ; and that the foregoing resolution was adopted at such meeting
by the vote shown above, I further certify that as of _____ ,
the date of closing of the loan from the United States Department of Agriculture, said resolution remains in effect and has not been
rescinded or amended in any way.

Dated, this _____ day of _____

Title _____

FOR APPROVAL

FOR APPROVAL

EMERGENCY ORDINANCE TO EFFECTUATE TEMPORARY CHANGES IN CERTAIN DEADLINES AND TO MODIFY PUBLIC MEETING AND PUBLIC HEARING PRACTICES AND PROCEDURES TO ADDRESS CONTINUITY OF OPERATIONS ASSOCIATED WITH PANDEMIC DISASTER.

WHEREAS, on March 12, 2020, Governor Ralph S. Northam issued Executive Order Fifty-One declaring a state of emergency for the Commonwealth of Virginia arising from the novel Coronavirus (COVID-19) pandemic; and

WHEREAS, Executive Order Fifty-One acknowledged the existence of a public health emergency which constitutes a disaster as defined by Virginia Code § 44-146.16 arising from the public health threat presented by a communicable disease anticipated to spread; and

WHEREAS, Executive Order Fifty-One ordered implementation of the Commonwealth of Virginia Emergency Operations Plan, activation of the Virginia Emergency Operations Center to provide assistance to local governments, and authorization for executive branch agencies to waive “any state requirement or regulation” as appropriate; and

WHEREAS, on March 13, 2020, the President of the United States declared a national emergency, beginning March 1, 2020, in response to the spread of COVID-19; and

WHEREAS, on March 11, 2020, the World Health Organization declared the COVID-19 outbreak a pandemic; and

WHEREAS, on March 23, 2020, the governing body of Amherst County, the Board of Supervisors, confirmed the declaration of local emergency made by the local director of emergency management; and

WHEREAS, the Board of Supervisors of Amherst County and the Town Council of the Town of Amherst finds that COVID-19 constitutes a real and substantial threat to public health and safety and constitutes a “disaster” as defined by Virginia Code §44-146.16 being a “communicable disease of public health threat;” and

WHEREAS, Virginia Code § 15.2-1413 provides that, notwithstanding any contrary provision of law, a locality may, by ordinance, provide a method to assure continuity of government in the event of a disaster for a period not to exceed six months; and

WHEREAS, Virginia Code § 44-146.21(C) further provides that a local director of emergency management or any member of a governing body in his absence may upon the declaration of a local emergency “proceed without regard to time-consuming procedures and formalities prescribed by law (except mandatory constitutional requirements) pertaining to performance of public work;” and

WHEREAS, Virginia Code § 2.2-3708.2(A)(3) allows, under certain procedural requirements including public notice and access, that members of Council may convene solely by electronic means “to address the emergency;” and

WHEREAS, the open public meeting requirements of the Virginia Freedom of Information Act (“FOIA”) are limited only by a properly claimed exemption provided under that Act or “any other statute;” and

WHEREAS, the Governor and Health Commissioner of the Commonwealth of Virginia and the President of the United States have recommended suspension of public gatherings of more than ten attendees; and

WHEREAS, The Attorney General of Virginia issued an opinion dated March 20, 2020 stating that localities have the authority during disasters to adopt ordinances to ensure the continuity of government; and

WHEREAS, this emergency ordinance in response to the disaster caused by the COVID-19 pandemic promotes public health, safety and welfare and is consistent with the law of the Commonwealth of Virginia, the Constitution of Virginia and the Constitution of the United States of America.

NOW, THEREFORE, BE IT ORDAINED by the Town Council of the Town of Amherst, Virginia:

1. That the COVID-19 pandemic makes it unsafe to assemble in one location a quorum for public bodies including the Town Council, the Planning Commission, Board of Zoning Appeals, Industrial Development Authority, and all local and regional boards, commissions, committees and authorities created by the Council or to which the Council appoints all or a portion of its members (collectively “Public Entities” and individually “Public Entity”), or for such Public Entities to conduct meetings in accordance with normal practices and procedures.
2. That in accordance with Virginia Code § 15.2-1413, and notwithstanding any contrary provision of law, general or special, the following emergency procedures are adopted to ensure the continuity of government during this emergency and disaster:
 - a. Any meeting or activities which require the physical presence of members of the Public Entities may be held through real time electronic means (including audio, telephonic, video or other practical electronic medium) without a quorum physically present in one location; and
 - b. Prior to holding any such electronic meeting, the Public Entity shall provide public notice of at least 3 days in advance of the electronic meeting identifying how the public may participate or otherwise offer comment; and
 - c. Any such electronic meeting of Public Entities shall state on its agenda and at the beginning of such meeting that it is being held pursuant to and in compliance with this Ordinance; identify Public Entity members physically and/or electronically present; identify the persons responsible for receiving public comment; and identify notice of the opportunities for the public to access and participate in such electronic meeting; and
 - d. Any such electronic meeting of the Public Entities shall be open to electronic participation by the public and closed to in-person participation by the public; and
 - e. For any matters requiring a public hearing, public comment may be solicited by electronic means in advance and shall also be solicited through telephonic or other electronic means

during the course of the electronic meeting. All such public comments will be provided to members of the Public Entity at or before the electronic meeting and made part of the record for such meeting; and

- f. The minutes of all electronic meeting shall conform to the requirements of law, identify how the meeting was conducted, members participating, and specify what actions were taken at the meeting. The Public Entities may approve minutes of an electronic meeting at a subsequent electronic meeting and shall later approve all such minutes at a regular or special meeting after the emergency and disaster has ended.

IT IS FURTHER ORDAINED that notwithstanding any provision of law, regulation or policy to the contrary, any deadlines requiring action by a Public Entity, its officers (including Constitutional Officers) and employees of its organization shall be suspended during this emergency and disaster, however, the Public Entities, officers and employees thereof are encouraged to take such action as is practical and appropriate to meet those deadlines. Failure to meet any such deadlines shall not constitute a default, violation, approval, recommendation or otherwise.

IT IS FURTHER ORDAINED, that non-emergency public hearings and action items of Public Entities may be postponed to a date certain provided that public notice is given so that the public are aware of how and when to present their views.

IT IS FURTHER ORDAINED, that the provisions of this Emergency Ordinance shall remain in full force and effect for a period of 60 days, unless amended, rescinded or readopted by the Council in conformity with the notice provisions set forth in Virginia Code §15.2-1427 but in no event shall such ordinance be effective for more than 6 months. Upon rescission by the Council or automatic expiration as described herein, this emergency ordinance shall terminate and normal practices and procedures of government shall resume.

Nothing in this Emergency Ordinance shall prohibit Public Entities from holding in-person public meetings provided that public health and safety measures as well as social distancing are taken into consideration.

An emergency is deemed to exist, and this ordinance shall be effective upon its adoption.

ADOPTED by the _____ .

APPROVED

ATTEST:

APPROVED AS TO FORM:

FOR APPROVAL

RESOLUTION OF THE TOWN OF AMHERST

**AUTHORIZING THE ADOPTION OF PROCEDURES FOR ELECTRONIC PUBLIC MEETINGS
AND PUBLIC HEARINGS TO ENSURE THE CONTINUITY OF
GOVERNMENT DURING
THE COVID-19 PANDEMIC DISASTER**

WHEREAS, on March 12, 2020, Governor Ralph S. Northam issued Executive Order Fifty-One declaring a state of emergency for the Commonwealth of Virginia arising from the novel Coronavirus (COVID-19) pandemic; and

WHEREAS, Executive Order Fifty-One acknowledged the existence of a public health emergency which constitutes a disaster as defined by Virginia Code § 44-146.16 arising from the public health threat presented by a communicable disease anticipated to spread; and

WHEREAS, Executive Order Fifty-One ordered implementation of the Commonwealth of Virginia Emergency Operations Plan, activation of the Virginia Emergency Operations Center to provide assistance to local governments, and authorization for executive branch agencies to waive “any state requirement or regulation” as appropriate; and

WHEREAS, on March 13, 2020, the President of the United States declared a national emergency, beginning March 1, 2020, in response to the spread of COVID-19; and

WHEREAS, on March 11, 2020, the World Health Organization declared the COVID-19 outbreak a pandemic; and

WHEREAS, on March 23, 2020, the governing body of Amherst County (the Board of Supervisors) confirmed the declaration of local emergency made by the local director of emergency management, specifically finding that the COVID-19 Pandemic constitutes a “disaster” as defined in Virginia Code § 44-146.16, being a “communicable disease of public health threat”; and

WHEREAS, Virginia Code § 15.2-1413 provides that, notwithstanding any contrary provision of law, a locality may, by ordinance, provide a method to assure continuity of government in the event of a disaster for a period not to exceed six months; and

WHEREAS, on April 8, 2020, the governing body of the Town of Amherst (the Town Council), pursuant to Virginia Code § 15.2-1413, adopted an Emergency Ordinance to Effectuate Temporary Changes in Certain Deadlines and to Modify Public Meeting and Public Hearing Practices and Procedures to Address Continuity of Operations Associated with Pandemic Disaster (“Emergency Ordinance”); and

WHEREAS, through its Emergency Ordinance, the Town Council specifically found that COVID-19 constitutes a real and substantial threat to public health and safety and constitutes a “disaster” as defined by Virginia Code § 44-146.16 being a “communicable disease of public health threat” and

WHEREAS, through its Emergency Ordinance, the Town Council further found that the COVID-19 pandemic makes it unsafe to assemble in one location a quorum for public bodies including the Town Council, the Planning Commission and all local and regional boards, commissions, committees and authorities created by the Town Council or to which the Town Council appoints all or a portion of its members (collectively “Public Entities” and individually “Public Entity”), or for such Public Entities to conduct meetings in accordance with normal practices and procedures; and

WHEREAS, through its Emergency Ordinance, the Town Council adopted certain procedures to ensure the continuity of government during the COVID-19 Pandemic disaster (“Continuity Procedures”), suspended any deadlines applicable to Public Entities and their staff during the COVID-19 disaster, and authorized Public Entities, at their discretion, to postpone non-emergency public hearings and action items during the disaster; and

NOW, THEREFORE, BE IT RESOLVED that the Town of Amherst Town Council hereby incorporates by reference and adopts the Continuity Procedures prescribed in the Emergency Ordinance, a copy of which is attached hereto; and

BE IT FURTHER RESOLVED that the Town of Amherst Town Council hereby authorizes and directs its officers and staff to take all steps reasonably necessary or appropriate to implement such Continuity Procedures and to develop any specific procedures as applicable and appropriate for the Town of Amherst, provided that such specific procedures are

consistent with the terms and conditions of the Emergency Ordinance; and

BE IT FURTHER RESOLVED that this Resolution shall take effect immediately upon adoption and shall remain in effect during the pendency of the Emergency Ordinance including for any applicable period upon the re-adoption of the Emergency Ordinance by Town Council.

ADOPTED by the _____ .

APPROVED

ATTEST:

APPROVED AS TO FORM:

FOR APPROVAL

AN ORDINANCE TO AMEND THE CODE OF THE TOWN OF AMHERST BY ADDING SECTION 4.24 THROUGH 4.27 OF CHAPTER 4, ARTICLE II OF THE TOWN CODE, THE AMENDED CODE REFERRING TO ANIMALS - DOGS AND CATS

Be it Ordained by the Council of the Town of Amherst:

2. *That Sec. 4.24 through Sec. 4.27 of the Code of the Town of Amherst are hereby added to read as follows:*

Sec. 4.24 - Running at large.

During all months of the year, it shall be unlawful for the owner of any dog to permit his dog to run at large within the town.

For the purposes of this article running at large shall mean the act of roaming, running or self-hunting off the property of its owner or custodian and not under the immediate control of its owner or custodian.

Sec. 4.25 - Leash law.

(a) It shall be unlawful for the owner, custodian or any person having a dog in his possession to fail to keep and maintain the dog under restraint and control at all times off of the owner's property.

(b) For the purposes of this section, a dog is deemed under restraint and control only when:

(1) The dog is securely confined within a parked or moving motor vehicle; or

(2) The dog is properly confined within a secure enclosure with the permission of the owner of the property where the enclosure is located; or

(3) The dog is securely restrained by either a secure collar and leash, discernable voice command, or other device, not harmful to the dog, having a minimum tensile strength sufficiently in excess of that required to restrict the dog's movements to a radius of no more than three (3) feet of the person owning, having custody of or possessing the dog who shall be physically capable of restricting the dog's movements if the dog is on a sidewalk, street or parking area. Where there are no other dogs or people present, the dog may be within 50 feet of the custodian.

(c) This section shall not apply to any person whose dog is under the direct supervision while such dog is participating in a supervised dog show or exhibition, or in a formal dog obedience training class or program.

(Ord. of 6-18-92; Ord. of 7-14-92)

Sec. 4.26 - Unlawful to allow dogs to defecate on public or private property; exception.

It shall be unlawful for any owner or person in custody of a dog to knowingly or willfully allow the dog to defecate on public property or the private property of other persons without the consent of such persons except that defecation by a dog shall not constitute a violation of this section if the owner or person in custody of the dog immediately removes the material defecated and disposes of it in a safe and sanitary manner.

Sec. 4.27 - Violation of article.

Any violation of the provisions of this article shall constitute and be punishable as a Class 4 misdemeanor and incur a \$50 penalty.

3. *That this Ordinance shall be effective on the 1st day of June, 2020.*

This ordinance was adopted on the 8th day of April, 2020.

D. Dwayne Tuggle, Mayor

ATTEST:

Clerk of the Council

Town Manager's Report for the May 13, 2020 Town Council Meeting

Committee	Report
A. Industrial Development Authority	Meeting held May 4, minutes attached
B. Planning Commission	No meeting/no report
C. Board of Zoning Appeals	No meeting/no report
D. Property Maintenance Investigation Board	No meeting/no report
E. Community Relations Committee	No meeting/no report
F. Finance Committee	No meeting/ no report
G. Utilities Committee	No meeting/no report
H. Town/Sweet Briar Sewer Use Advisory Commission	No meeting/no report
I. Lynchburg Regional Business Alliance	CVTC-TAG meeting held on May 4
J. Central Virginia Planning District Commission	No meeting/no report
K. Amherst County Chamber of Commerce	No meeting/no report



AMHERST POLICE DEPARTMENT



MONTHLY REPORT

April 2020

Month:	SHIFT WORKING:
OFFICER:	VEHICLE:
MILEAGE START OF SHIFT:	MILEAGE END OF SHIFT:

CALLS FOR SERVICE	NUMBER
MOTORIST ASSIST	14
ALARM	14
PHONE COMPLAINT	104
BOLO	5
MISSING PERSON	
SHOPLIFTING	
PROBLEM WITH OTHERS	9
DOMESTIC	
CHECK WELFARE	4
NOISE OR DOG COMPLAINT	4
TRAFFIC CRASH	1
EMS CALLS	4
SUDDEN DEATH	
SUSPICIOUS PERSON	3
Call at Ambriar	1
OTHER	22

OFFICER INITIATED	NUMBER
BUILDING CHECKS	194
BUSINESS VISIT	22
BUILDING SEARCH	6
TRAFFIC SUMMONS	
DRUNK IN PUBLIC	
EXTRA PATROLS/ Parks	70/47
WARRANT SERVICE	
PROPERTY WALK AROUNDS	39
WARRANTS OBTAINED	1
PARKING TICKETS	
MISD. INVESTIGATION	2
FELONY INVESTIGATION	1
NARCOTICS INV.	
SEARCH WARRANT	
PUBLIC RELATIONS	
CITIZEN CONTACT	76

WARNINGS	NUMBER
SPEEDING	
EQUIPMENT VIOLATION	
RECKLESS DRIVING	
SUSPENDED LICENSE	
INSPECTION/REGISTRATION	
SEAT BELT / TEXTING	
ALL OTHER VIOLATIONS	1

TRAFFIC STOPS TICKETED	NUMBER
SPEEDING	
EQUIPMENT VIOLATION	
RECKLESS DRIVING	
SUSPENDED LICENSE	
INSPECTION/REGISTRATION	
SEAT BELT / TEXTING	
ALL OTHER VIOLATIONS	

ARREST	NUMBER
MISDEMEANOR	1
FELONY	
EPO/PPO	
ECO	
NARCOTICS VIOLATION	
DUI / DUIG	

OTHER	NUMBER
ASSIST OTHER OFFICER	16
ASSIST OTHER AGENCY	17
COURT	
REPORTS	6
SCHOOL / TRAINING	84hrs/12hrs
MEETINGS	2
TOWED / IMPOUNDED VEH	



AMHERST POLICE DEPARTMENT



MONTHLY REPORT

PLEASE LIST ALL PASS ON'S, INVESTIGATIONS, ARREST, IMPOUNDED VEHICLES WITH REASON AND LOCATION, AND BUSINESSES WITH OPEN DOORS OR ANY OTHER SIGNIFICANT COMPLAINTS.

Calls for service-110

Miles patrolled- 4,461

County assists:

4/13- Mental Health call. Cleared advice

4/14- Vehicle crash 29 South & Coolwell Rd. Assist VSP.

4/15- Warrant Tomlin Rd. No contact.

4/17- Problems with others. Advice

4/20- Attempt to locate welfare check.

4/22- Attempt to locate a person wanted on a Felony warrant on Little Piney Rd.
No contact.

Chief B. Shiflett completed 40 hours of Law Enforcement online in service.

Maj. G. Harler completed 40 hours of Law Enforcement online in service.

Firearm qualification done.



TOWN OF AMHERST

P.O. Box 280 174 S. Main Street Amherst, VA 24521
Phone (434)946-7885 Fax (434)946-2087

To: Town Council
From: Tracie Wright
Date: May 5, 2020
Re: April 2020 Monthly Report

Utilities – 1162 bills were cut totaling \$158,691.70

A/P – A total of 50 checks were cut totaling \$154,364.99 for April 2020 bills.

Meals and Beverage Tax – 13 Businesses paid \$34,758 in Meals and Beverage Tax for the month of March. This is already roughly a \$6,000 drop from normal taxes paid.

Taxes – As of May 5, 2020 we have a total of \$4,035.00 in outstanding 2019 bills. Therefore, we received \$2,000 as a result of the bank lien process.

New Financial Software – While I have been home on maternity leave, I have been spending some time with the setup of the new software. Hopefully we will stay on track for a July 1st live payroll.

Business License – As of May 5, 2020 we have received a total of \$64,630.89 in Business License payments. This is roughly half of the budgeted amount for the 2020 FY.

Upcoming Items –

- New version of the FY21 budget to reflect adjustments as a result of the Coronavirus.

Front Office – Everything seems to be running smooth with few complaints even though the office is closed to the public.

I will be returning full-time from maternity leave May 18th, 2020.

**CLERK OF COUNCIL REPORT
APRIL 2020**

COMMITTEE MEETINGS

Town Council

Receive and review agenda packet for 4-8-20 meeting; post agenda packet to website; prepare for and attend meeting; draft minutes for approval; post to Town website

Quorums: Town Council meetings; Confirm/notify cancellation of meeting with members of Planning Commission and Industrial Development Authority

TOWN WEBSITE DESIGN AND CONTENT MANAGEMENT

Administration of website generating and revising web pages; examining traffic through the site; design for overall look and feel of the site, including photos, color, graphics and layout; creating, editing, posting, updating, and occasionally cleaning up outdated content.

TOWN FACEBOOK ADMINISTRATOR

- Create content and/or design and post:
 - Post Town Council Meeting Procedures
 - Post Cancellation of Amherst County Fair
 - Share Amherst Graduation Ceremony Information
 - Create Reminder and Post Town Hall Closure to General Public and Business
- Share links to community events and news; Monitor feedback

FOIA

Receive and answer two (2) requests

OTHER:

- Draft for approval Day of Prayer Proclamation
- Prepare procedures for Amherst Town Council Meetings during Covid-19 pandemic restrictions
- Attend webinars re virtual meeting/admin/security procedures
- Research how to disable Ipad speaker
- Create YouTube account; research YouTube; test livestreaming
- Attend test webinar session
- Prepare, send, post Legal Ads/Public Hearing Notice: Town Council PH 4/8/20

- Prepare miscellaneous purchase orders

Town of Amherst Committees as of April 30, 2020 Update; See Attached.

Town of Amherst Committees as of April 30, 2020

Appointed/Term Expires

TOWN COUNCIL

D. Dwayne Tuggle, Mayor	01/01/19	12/31/22
Rachel A. Carton, Vice Mayor	01/01/19	12/31/20
Kenneth S. Watts	01/01/19	12/31/22
Sarah B. Ogden	01/01/19	12/31/20
Kenneth G. Bunch	01/01/19	12/31/20
Janice N. Wheaton	11/12/19	12/31/22

PLANNING COMMISSION

June Driskill, Chairperson	06/08/16	06/30/20
Janice N. Wheaton	12/11/10	12/31/20 (TC rep)
William Jones	07/01/10	06/30/23
Ted Finney	07/01/17	06/30/21
Kevin Belcher	07/01/18	06/30/22
Clifford Hart	07/01/19	06/30/23
Anne Webster Day	03/13/19	06/30/22

BOARD OF ZONING APPEALS

Gary Mays, Chairman	04/08/15	08/31/20	Vacancy occurring 8/31
Ed Carton	09/01/19	08/31/24	
Teresa Tatlock	07/10/16	08/31/21	
Marvin Hensley	08/31/17	08/31/22	
Kevin James Akershoek	09/01/18	08/31/23	Vacancy Advertised

INDUSTRIAL DEVELOPMENT AUTHORITY

Clifford Hart	09/01/19	08/31/23
Sharon Watts Turner	07/01/18	06/30/22
Gary Jennings	05/10/17	06/30/21
Jacob Bailey	06/08/16	06/30/20
Manly Rucker	05/10/17	06/30/21
Kim Odell Stein	07/11/18	06/30/22
Richard Wydner	07/01/19	06/30/23

PROPERTY MAINTENANCE INVESTIGATION BOARD

C. Manly Rucker, III	05/10/17	06/30/20
Bessie H. Kirkwood	07/01/18	06/30/22
Glenda Hash	06/08/16	06/30/20

REGION 2000 REGIONAL COMMISSION/MPO

D. Dwayne Tuggle	01/01/19	12/31/20
Sara Carter	01/01/19	12/31/20

Appointed/Term Expires

CENTRAL VIRGINIA TRANSPORTATION COUNCIL (MPO)

D. Dwayne Tuggle	01/01/19	12/31/20
Sara E. Carter	01/01/19	12/31/20

TOWN/SWEET BRIAR SEWER USE ADVISORY COMMISSION

Clifford Hart	01/01/19	12/31/20
Kenneth S. Watts	01/01/19	12/31/20

JOINT COMMITTEE ON COOPERATION

Kenneth S. Watts	01/01/19	12/31/20
Kenneth G. Bunch	01/01/19	12/31/20
Sarah B. Ogden	01/01/19	12/31/20

(3 Appointments from Amherst County)

TOWN COUNCIL COMMITTEES (FOR THE 01/01/19-12/31/20TERM)
--

FINANCE COMMITTEE

- Rachel A. Carton (Chairman) and Kenneth S. Watts
- Monitor the budget development process.
 - Review accounting procedures, budgets, and bookkeeping activities.
 - Interface with auditors.

COMMUNITY RELATIONS AND RECREATION COMMITTEE

- Sarah B. Ogden (Chairman) and Rachel A. Carton
- Monitor and review implementation of the Town's bike trails and public parks
 - Review the Town's beautification efforts and programs.
 - Interface with citizens, business operators, Sweet Briar College and VDOT

UTILITIES COMMITTEE

- Kenneth S. Watts (Chairman) and Kenneth G. Bunch
- Monitor the development and construction of capital improvement projects.
 - Review proposed utility system upgrades and extensions.
 - Interface and assist developers in coordinating Town policies with proposed new developments.

RECODIFICATION COMMITTEE

- Kenneth G. Bunch (Chairman) and Kenneth S. Watts
- Monitor the recodification of Town Code process
 - Review proposed proof and edits

AD HOC COMMITTEE – PERSONNEL PERFORMANCE EVALUATION FORMS

- Kenneth G. Bunch (Chairman) and Rachel A. Carton
- Review and make revisions to the Town's Personnel Employee Performance Evaluation and Employee Self-Performance Evaluation Forms edits

Utility/Town Maintenance and Construction Report

Apr-20

Water Meter Read	1150
Water Meter Re-Read	46
Disconnects	0
VA-811 Service locations	27
Vehicle PM Work Orders	26
Pump Station/Plant Work Orders	24
Banners Installed/Dismantled	0
Water Services Installed/Replaced	0
Sewer Services Installed/Replaced	0
Minor Leaks ks Repaired	2
Major Leaks Repaired	0
Minor Sewer Problems Resolved	5
Major Sewer Problems Resolved	3

10

Man Hours

Meter Reading	64
Street/Sidewalk Maintenance	235
Safety Training	2
Bush Hogging	0
Flushing Water	0
Equipment Maintenance	128
Xmas decorations	0

Major Issues & Comments

Routine/Annual Work

Projects/Unusual Work

Service Work Orders Meter Reading Prev-Maint Work Orders Disconnects Re-connects Flushing Program in Select Locations	Locating Un-marked/Unknown Water & Sewer System Assets Continue Safety and Shop/Yard Clean-up Staff has been working on finding water valves and addressing issues Working on clearing water right of ways.
---	--



TOWN OF AMHERST
DEPARTMENT OF PLANTS

MONTHLY PRODUCTION AND OPERATIONAL REPORT
 April -- 2020

SUBMITTED BY: GARY S. WILLIAMS,
 DIRECTOR OF PLANTS

SUBMISSION DATE: May 5, 2020

Grandview Water Filtration Plant,

Daily Water Withdrawal and Production:

	Total, million gallons	Average, million gallons	Max, million gallons	Min, million gallons
Raw Water	7.500	0.290	0.480	0.100
Produced	6.630	0.250	0.420	0.100
Delivered	6.370	0.240	0.420	0.080

Rutledge Creek Wastewater Treatment Plant,

Daily Received and Treated Waste Stream:

	Total, million gallons	Average, million gallons	Max, million gallons	Min, million gallons
Raw Influent	9.619	0.321	1.007	0.183
Final Effluent	9.097	0.303	0.991	0.181

Rainfall on the morning of Monday, April 13, 2020, was recorded at 3.3 inches and was an event that caused local flooding and, in some areas, mudslides. The Rutledge Creek, as seen below, breached its banks and flowed into the flood plain at the Rutledge Creek WWTP. The picture below shows the flooding that occurred.



The raw influent flow was recorded at being 1,006,700 gallons for the day. While the WWTP is designed to handle the occasional million-gallon daily flows, the flushing effect that the rain that day had a flushing effect

on the Towns wastewater collection system overburdening the facilities “Headworks” causing channel breaching.

Because of the amount of debris being swept in by the high flows, plant equipment could not keep up with the removal and thus causing the incoming flows to spill out of the main channel. The headworks design is such that overflows of this nature are still contained in a tank-like setting and then flows back into the canal after flowing around the blockage as the picture below shows.



Staff continued to work with process control for the day to maintain treatment and disinfection as well as cleaning. By the end of the day, all process units work back online, and normal operations were reinstated.



W. THOMAS BERRY
ATTORNEY AT LAW
TAN BARK PROFESSIONAL BUILDING, COURT STREET
P.O. BOX 354 * 402 COURT STREET
LOVINGSTON, VIRGINIA 22949

W. THOMAS BERRY

OFFICE PHONE
434-263-4886
Fax: 434-263-4285

May 1, 2020

Town of Amherst
P.O. Box 280
Amherst, VA 24521

Attn: Sara Carter- Town Manager

Re: Monthly Report to Town Council
(April 2020)

Dear Ms. Carter and Council,

My report on work regarding the following matters:

1. Town Council Meeting: Did not attend the monthly scheduled meeting on April 8, 2020.
2. Personnel: Review of Town of Amherst Police Department Policy and Procedure, finalized and sent to Chief Shifflett.
3. Business:
 - A: Closed Slip Line Project.
 - B: Operation of Government/Emergency.
 - C: Review contract for Waste Treatment Plant.
4. Upcoming Work:
 - A: Emergency Policy/Pandemic.
 - B: Address upcoming County/Town Planning.
5. Access to Town Attorney: My email address is dawn@tomberrylaw.com. Please feel free to use this email access provided, and I will promptly return any communication. My home phone (434) 946-9501; office phone (434) 263-4886.

Respectfully Submitted,



W. Thomas Berry

WTB/tpg

W. THOMAS BERRY, LLC

ATTORNEY-AT-LAW

P.O. BOX 354/ 402 COURT STREET

LOVINGSTON, VA 22949

PHONE: (434) 263-4886

Invoice

Date	Invoice #
5/1/2020	9300

Bill To
Town of Amherst c/o Sara Carter P.O. Box 280 Amherst, VA 24521

			Terms
			Due on receipt
Description	Qty	Rate	Amount
4/6/2020 Review Town Package	1.5	175.00	262.50
4/22/2020 Research Agreement on Construction and Corona	1.5	175.00	262.50
4/28/2020 Review Police Policy	3.5	175.00	612.50
4/29/2020 Finalized Review of Police Policy	3.5	175.00	612.50
Total			\$1,750.00
Payments/Credits			\$0.00
Balance Due			\$1,750.00

This is **EXHIBIT K**, consisting of **2** pages, referred to in and part of the **Agreement between Owner and Engineer for Professional Services** dated **March 20, 2018**.

**AMENDMENT TO OWNER-ENGINEER AGREEMENT
Amendment No. 2**

The Effective Date of this Amendment is: **April 24, 2020**.

Background Data

Effective Date of Owner-Engineer Agreement: **March 20, 2018**

Owner: **Town of Amherst, Virginia**

Engineer: **WW Associates, Inc.**

Project: **Sanitary Sewer Rehabilitation and Replacement**

Nature of Amendment:

 X Additional Services to be performed by Engineer

Description of Modifications:

Construction Stakeout Services

Agreement Summary:

Original agreement amount:	\$ <u>415,500</u>
Net change for prior amendments:	\$ <u>161,000</u>
This amendment amount:	\$ <u>8,500</u>
Adjusted Agreement amount:	\$ <u>585,000</u>
Change in time for services (days or date, as applicable):	<u>0 days</u>

The foregoing Agreement Summary is for reference only and does not alter the terms of the Agreement, including those set forth in Exhibit C.

Owner and Engineer hereby agree to modify the above-referenced Agreement as set forth in this Amendment. All provisions of the Agreement not modified by this or previous Amendments remain in effect.

OWNER: **Town of Amherst, Virginia**

ENGINEER: **WW Associates, Inc.**

By: _____
Print
name: Sara E. Carter

Title: Town Manager

Date Signed: _____

By: 
Print
name: Herbert F. White III, P.E.

Title: President

Date Signed: 4/24/2020

**Town of Amherst
Industrial Development Authority**

A regular meeting of the Town of Amherst Industrial Development Authority was called to order by Chairman Jacob Bailey on May 4, 2020, at 5:15 PM in the Council Chambers of the Town Hall at 174 S. Main Street. It was noted that a quorum was present as follows:

P	Richard Wydner	P	Sharon W. Turner
P	Jacob Bailey	P	Kim Stein
A	Gary Jennings	P	Clifford Hart
P	C. Manly Rucker, III		

Town Manager Sara E. Carter, in her capacity as Secretary to the Authority, and Clerk of Council Vicki Hunt, were present.

Ms. Turner made a motion which was seconded by Mr. Rucker to approve the minutes of the February 3, 2020, meeting. There being no discussion, the motion carried 6-0 with Mrs. Turner and Messrs. Bailey, Wydner, Rucker, Stein and Hart voting “Aye”. Mr. Jennings was absent.

Report on Brockman Business and Industrial Park

After a prerecorded video presentation of a proposal from Draper Aden for engineering services for the Brockman Business and Industrial Park, and discussion, by consensus Secretary Carter was instructed to work on an application for a GO Virginia grant to defray some of the cost involved in the proposed project. Further discussion is deferred on the matter.

Ms. Turner made a motion that was seconded by Mr. Wydner that the Industrial Development Authority convene in closed session for discussion concerning an economic development prospect where no previous announcement has been made regarding a possible use at the Brockman Industrial Park, as provided by the Code of Virginia at §2.2-3711A.5 of the Code of Virginia. The motion carried 6-0 with Mrs. Turner and Messrs. Bailey, Wydner, Rucker, Stein and Hart voting “Aye”. Mr. Jennings was absent.

Chairman Bailey adjourned the open session at 6:14 pm.

The meeting reconvened in closed session. It was noted that a quorum was present as follows:

Jacob Bailey	Present	C. Manly Rucker, III	Present
Richard Wydner	Present	Sharon W. Turner	Present
Gary Jennings	Absent	Clifford Hart	Present
Kim Stein	Present		

At 6:33 PM, Ms. Turner made a motion, seconded by Mr. Wydner that the Industrial Development Authority adjourn the closed session and reconvene in open session, and that the members certify to the best of each member’s knowledge that (i) only public business matters lawfully exempted from open meeting requirements under Title 2.2, Chapter 37 and §15.2-2907 of the Code of Virginia and (ii) only such public business matters as were identified in the motion by which the closed session was convened were heard, discussed or considered in the session. The motion 6-0 via the roll call method with Ms. Turner and Messrs. Bailey, Wydner, Rucker, Stein and Hart voting “Aye”. Mr. Jennings was absent.

There being no further business, the meeting adjourned at 6:35 PM.

Jacob Bailey, Chairman

ATTEST: _____
Secretary

FOR APPROVAL



IRON Lives, Inc.

PO Box 145

Amherst, VA

24521

Sabrina Graybill

sabrina@ironlives.com

April 23, 2020

To Whom It May Concern:

Prior to the global pandemic caused by COVID-19, IRON Lives, Inc. had scheduled a 5K Race event in the Town of Amherst for April 19, 2020. Due to the pandemic, and the social distancing orders placed by the state government, we decided to postpone the event.

During this time, we have kept an eye on research and projections, and we are interested in selecting a new date for the event. We would like to reschedule the 5K for Sunday, October 4, 2020. All previous details and aspects of the event will remain the same, only the date will change.

As a representative of IRON Lives, Inc., I would like to present this date change to the Amherst Town Council for approval. This approval will allow us to proceed with the changes necessary to implement this event on the new date. Thank you in advance for your assistance.

Best,
Sabrina Graybill
Director of Operations / 5K Director
IRON Lives, Inc.

Prepared by: W. Thomas Berry, Esquire

Return to: W. Thomas Berry, Esquire

Tax Map ID No.: 95-A-83 and 95-A-78A

THIS MEMORANDUM OF UNDERSTANDING, made and entered into this 12th day of March, 2020, by and between AMHERST COUNTY SCHOOL BOARD, hereinafter called "School Board," Grantor for the purpose of indexing, and THE TOWN OF AMHERST, hereinafter called "Town," Grantee for the purpose of indexing, whose address is 174 South Main Street, P.O. Box 280, Amherst, Virginia 24521.

WHEREAS, School Board is the owner of certain property, on which is located the Amherst County High School campus, and adjoins the lands of Town, being more particularly described as Tax Map Parcel No. 95-A-83, and being the property conveyed to Amherst County School Board by deed dated October 30, 1947, and recorded in the Office of the Clerk of Circuit Court of Amherst County, Virginia in Deed Book 135, page 231; and,

WHEREAS, Town is the owner of that certain property, on which is located the Amherst Town Park, and adjoins the lands of School Board, being more particularly described as Tax Map Parcel No. 95-A-78A, being the property conveyed to Town by deed dated January 18, 2019 and recorded in the Office of the Clerk of the Circuit Court of Amherst County, Virginia as Instrument Number 190000440 with plat recorded in Plat Cabinet 4, slide 4.

WHEREAS, the School Board property includes a utility easement for a waterline that is maintained by the Town. The Town and the School Board desire to enter into an agreement to allow the Town use of the lands contained within the utility easement for recreational purposes to include walking, hiking jogging and non-motorized biking.

WHEREAS, Town and School Board understand that the Amherst County Schools also make use of the property.

WHEREAS, the recreational use of the utility easement will enhance the use of the Amherst Town Park and benefit the School Board property.

NOW, THEREFORE, that for and in consideration of the premises and the mutual covenants contained herein, the parties hereby agree as follows:

1. School Board does hereby agree to allow Town the use of an area of land lying and being situate in the Court House District of Amherst County, Virginia, being more particularly described as "A Twenty Foot Utility Easement" as set forth in Utility Easement dated December 19, 2013, recorded in the Clerk's Office of the Circuit Court of Amherst County, Virginia in Deed Book 1249, page 340.
2. School Board hereby acknowledges that the use of the existing utility easement is for the purpose of recreational walking, hiking, jogging, and non-motorized biking. Town shall be permitted to mow and maintain the existing easement area, keeping it free from debris and obstruction.
3. Both Town and School Board understand that certain maintenance is required to keep the property in good condition for recreational use by the Town and normal use by the Amherst County Schools.
4. The Town agrees to provide regular police patrols of the easement area.
5. Town hereby agrees to indemnify, defend and save harmless School Board against and all liabilities, claims, expenses, costs, losses and damages, including, but not limited to reasonable attorney's fees, arising from or in connection with the Town's use of the subject area.

6. The term of this agreement shall be for a period of twenty-five (25) years and may be terminated during that time by either party upon a six (6) month written notice of termination mailed, by certified mail, return receipt requested, to the other party at the above address, or at such other address as a party may provide. Upon the termination of this agreement, Town shall leave the area clean and free of trash and debris. This agreement may be extended an additional twenty-five (25) years upon further written agreement.
7. This agreement contains the entire agreement between the parties and may be changed only by a written amendment, signed by both parties. This agreement shall be governed by the laws of the Commonwealth of Virginia. It shall not be assigned by Town without the prior written approval of School Board.

WITNESS the following signature and seals:



_____(seal)
Dr. Robert Arnold, Superintendent
Amherst County School Board

STATE OF VIRGINIA
CITY/COUNTY OF Amherst - to-wit:

The foregoing was acknowledged before me, in my jurisdiction aforesaid, this 1st day of April, 2020, by Dr. Robert Arnold, Superintendent, Amherst County School Board.

My commission expires: 9/30/2022

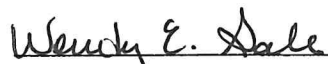
My Registration No: 7057808



Notary Public

WITNESS the following signature and seals:

_____(seal)
Dwayne Tuggle, Mayor
Town of Amherst

STATE OF VIRGINIA
CITY/COUNTY OF _____ - to-wit:

The foregoing was acknowledged before me, in my jurisdiction aforesaid, this _____
day of _____, 2020, by Dwayne Tuggle, Mayor, Town of Amherst.

My commission expires: _____

My Registration No: _____

Notary Public



194 Second Street
Amherst, Virginia
434.941.0997
SecondStageAmherst.org

To: Sara Carter, Town Manager and Amherst Town Council Members
From: Suny Monk, President, Second Stage
Subject: Changes in proposed project for FY20
Date: April 20, 2020

Even before the current global pandemic crippled business activity across the nation the Program Committee at Second Stage began to foresee delays in the student film project that was funded by the Town Council. Initially scheduled for fall 2019, Chris Badgett, board member, project leader and Choral Music Director at Amherst Middle School, enjoyed enthusiastic support from his principal, Mr. Kelly Holmes but was frustrated by delays in gaining signatures to authorize creation of a film club to oversee the series. Sensing the delays, the Program Committee offered a fall family film series titled Ramblin' Pictures which featured films about bluegrass and county music that would appeal to parents and children while we worked with students toward their spring screening schedule. This change was shared with the Town Manager in January as we struggled to meet the reporting deadlines for release of FY20 funds and to meet FY21 funding application deadlines.

Starting in January, the film club met weekly, selected movies, assigned design, marketing and screening tasks and were ready to begin advertising their spring film series, Movies That Made Us, when school was dismissed for the year.

The Board of Directors and Program Committee at Second Stage acknowledge that we haven't met the specifics of this year's request but believe we worked to meet the need of providing much sought-after entertainment for families in our town and surrounding county.

We request that the Town Council release the funds appropriated for the film project that has been completed. The original budget of \$3000 was meant to fund both series but with continuing stay-at-home orders and school dismissed for the remainder of the year, we see no way to complete the student-led portion. The Council wisely oversees accounting of public funds by requiring receipts for funded activities, but that is just not possible under these circumstances and we request that the remaining appropriated funds be released to cover operating expenses at Second Stage. Specifically, on April 9, despite greatly-reduced organizational income, we launched the 8th season of the 2nd St. Market as a drive-through option to serve our community by providing fresh, locally grown goods and as a sales outlet for our loyal vendors. We would greatly appreciate release of the remaining budgeted funds totaling \$531 to support that effort. If approved, we will supply receipts for staff and marketing costs associated with the market.

Thank you for your consideration. We doubt any of us could have imagined the way 2020 is unfolding. Please be assured, Second Stage continues to focus on enhancing public life in our community...needed now more than ever.

Itemized Expenses for Second Stage Film Series 2020

EXPENSE	Cash	Notes
STAFF	600	Penny's time for license/media/graphics designd 30 hours
SUPPLIES	15	Poster hanging supplies
EQUIPMENT	750	Use of facilities and Equipment
Food/bev	21.39	FL 9/27
Food/bev	20.45	FL 10/25
MOVIES (5)		
Licenses	800	
Purchase	12	
TOTAL EXPENSE	2218.84	

LEGEND

- FO..... FIBER OPTICS
- DE..... DRAINAGE EASEMENT
- SSE..... SANITARY SEWER EASEMENT
- P.I..... POINT OF INTERSECTION
- FH..... FIRE HYDRANT
- SSMH..... SANITARY SEWER MANHOLE
- VDOT..... VIRGINIA DEPARTMENT OF TRANSPORTATION
- OVERHEAD UTILITY LINES
- FENCE LINE
- UTILITY POLE
- GUY ANCHOR

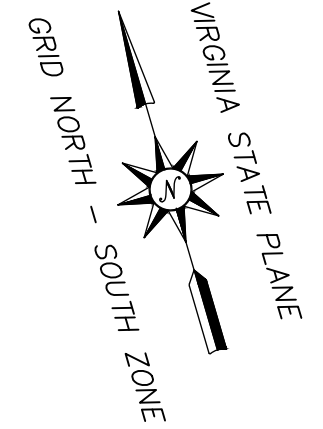

LOT 5 - BLOCK G
W.M. GANNAWAY SUBDIVISION
 PLAT BOOK 1 PAGE 30
 PATRICIA T. COOK
 TAX PARCEL 96A5-8-5
 DEED BOOK 1280 PAGE 281

CURVE C1:
 ARC LENGTH: 33.16'
 RADIUS: 20.00'
 TANGENT: 21.83'
 COURSE: N58°46'47"E
 CHORD: 29.49'

LINE TABLE		
LINE NO.	BEARING	DISTANCE
L1	N05°14'04"E	17.44'
L2	N13°40'18"W	24.51'
L3	N13°40'18"W	25.78'
L4	S22°19'50"W	77.83'
L5	N75°10'21"W	50.05'
L6	N64°54'30"E	83.44'
L8	S56°32'32"W	14.50'

TOTAL AREA
 8.904 ACRES

BOUNDARY SURVEY FOR
JOHN N. GORDON, III
 SHOWING THE RESIDUE OF LOTS 1-5
 AND ALL OF LOTS 6-12 - BLOCK B
 THE NORTHERN 100' OF LOTS 8-18 - BLOCK A
 MOUNTAIN VIEW SUBDIVISION
 -AND-
 THE RESIDUE OF LOTS 13A, 14, & 15 - BLOCK E
 AND THE RESIDUE OF BLOCKS F & G
 THOMAS WHITEHEAD SUBDIVISION
 TOWN OF AMHERST, VIRGINIA
 SURVEYED: JANUARY 27, 2020
 SCALE: 1" = 60'
 SHEET 2 OF 2

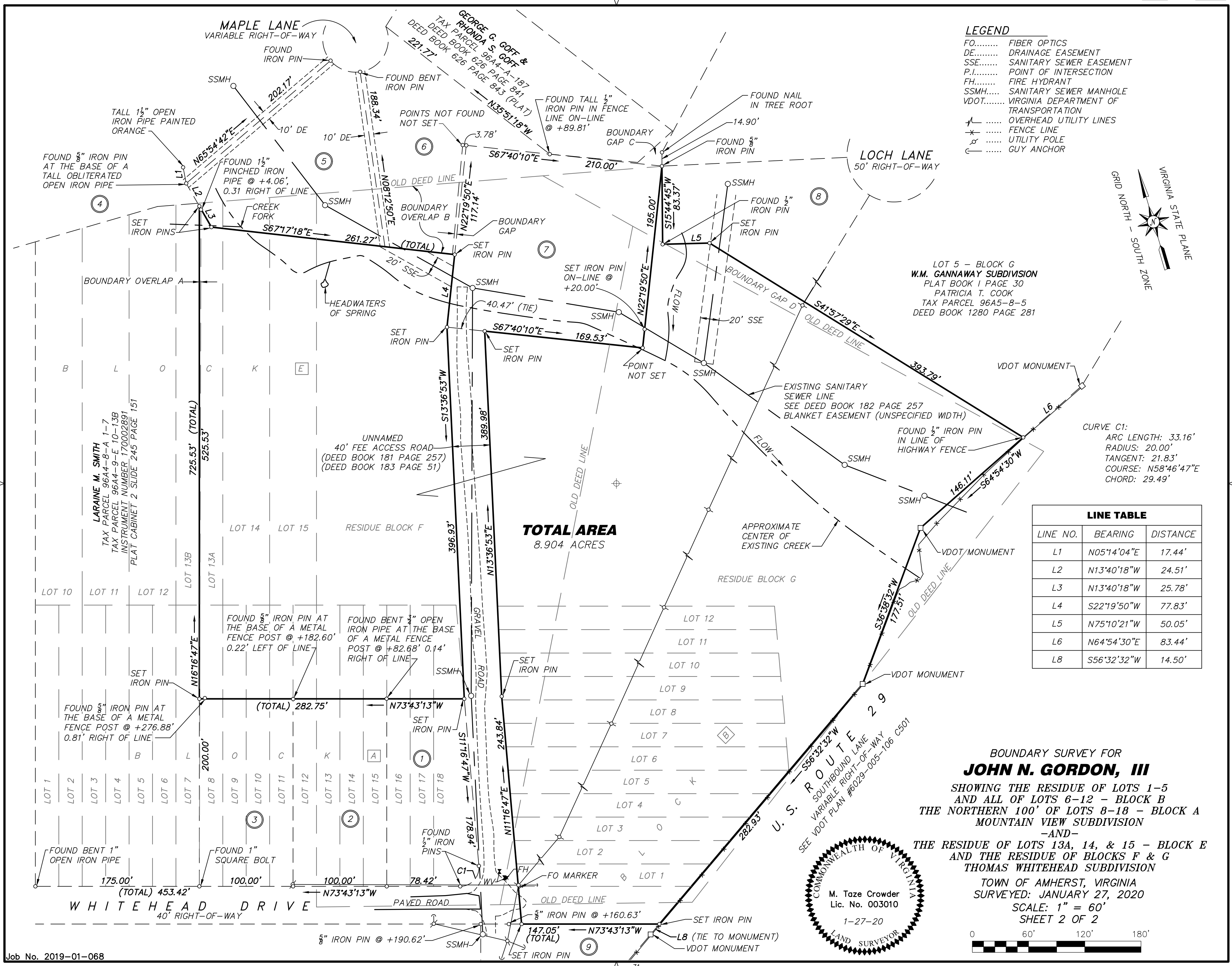
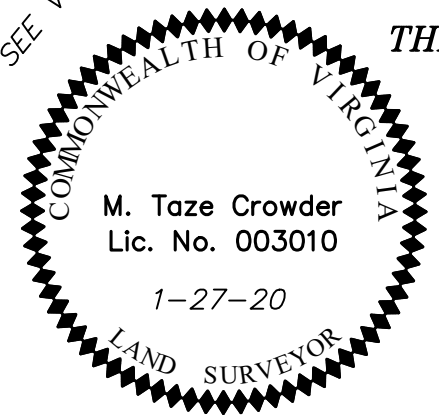

P.O. BOX 424 - AMHERST, VIRGINIA 24521-0424
 PHONE: 434-946-7300 - EMAIL: INFO@ACTUALSURVEYORS.COM
 WEB: WWW.ACTUALSURVEYORS.COM

ACTUAL SURVEYORS, PLLC

Sec. 18.1-908.06. Signs permitted in all sign districts.

- (a) The following signs shall be permitted in all sign districts and shall not require a sign permit, unless otherwise indicated. The area of any sign described in this subsection shall not be included in computing the aggregate sign areas specified for individual districts.
- (1) *Temporary signs.* Temporary signs, which shall be non-illuminated and limited to the following types:
- a. When buildings are under construction or sites are under development, signs may be displayed provided that they are removed upon issuance of a certificate of occupancy. The maximum sign area of each such sign shall be 32 square feet.
 - b. When a property is offered for lease or for sale, signs may be displayed provided that they are removed within five days of the date of closing or within five days of the beginning of the lease.
 - 1. In the residential sign and mixed use districts, the maximum aggregate sign area shall be four square feet and the maximum height shall be twelve feet.
 - 2. In the commercial and industrial sign district, the maximum aggregate sign area shall be thirty-two square feet and the maximum height shall be twelve feet.
 - c. When a business in the mixed use or commercial and industrial sign district opens, temporary building-mounted signs and banners shall be permitted, provided that such sign or signs shall not be displayed for more than 30 days. The maximum aggregate sign area shall be 32 square feet.
 - d. When a dwelling in a residential sign district is holding a yard sale, signs may be displayed for only 48 hours and only on the property where the yard sale will be held.
 - e. For special events within the Town, any property owner may display up to two signs of up to four square feet each for up to five days in any 60 day period.
 - f. Signs on private property that exercise the property owner's right to right to free speech and express non-commercial messages such as ideals, causes, policies or candidates, provided that the aggregate sign area is not larger than 40 square feet in the mixed use and commercial and industrial sign districts or 16 square feet in the residential and agricultural sign district, and the total number of signs on a parcel cannot exceed two. Such signs shall be removed within 60 days of installation, and no property can display such signs for more than a total of 120 days per year.
- (2) *Permanent signs.*
- a. One sign at each parking lot entrance with no commercial logo or other message and not exceeding three square feet in area.
 - b. Non-illuminated names of buildings, dates of erection, monumental citations, commemorative tablets, insignia of local, state or federal government, and like when carved into stone, concrete or similar material or made of bronze, aluminum or other permanent type construction and made an integral part of a building structure. The maximum size of such sign shall be 32 square feet.
 - c. Usual and customary signs identifying disabled parking, rest rooms, directions, driving instructions or other facilities relating to such places or activities.
 - d. Signs not visible from adjacent properties or public rights-of-way.
- (3) *Flags.* Flags containing no commercial message are not regulated.
- (4) *Works of Art.* Works of art that do not contain any commercial messages or references and are constructed or displayed under the auspices of a locally based civic group, nonprofit or government agency.
- (5) *Location on right of way.* Signs installed on VDOT right of way under a VDOT permit. The Town will only assist in the VDOT permitting process with Town approved banners installed above S. Main Street on the existing banner bracket.
- (6) *Nonconforming.* Any sign may remain in use provided that it was lawful at the time this ordinance was enacted. However, signage for any business shall be required to conform to all requirements of this ordinance as a condition of approval before any change to the signage for that business.

Amherst LOVE sign

*dimensions and
proportions are
approximate*

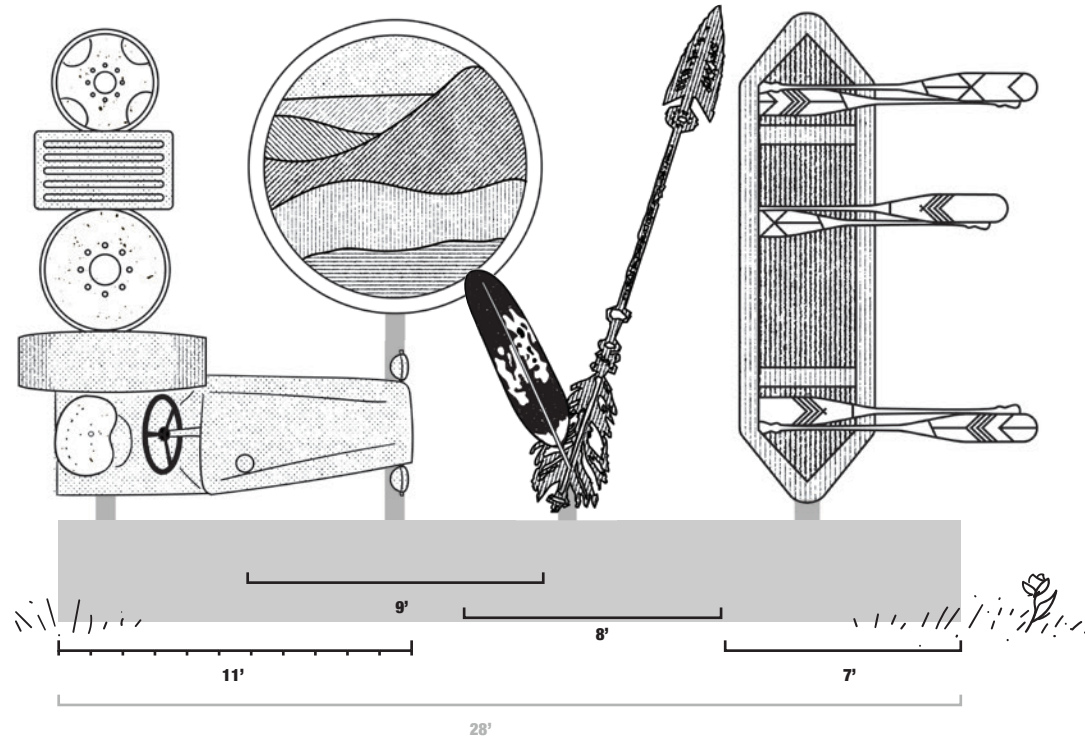

L - DECONSTRUCTED TRACTOR

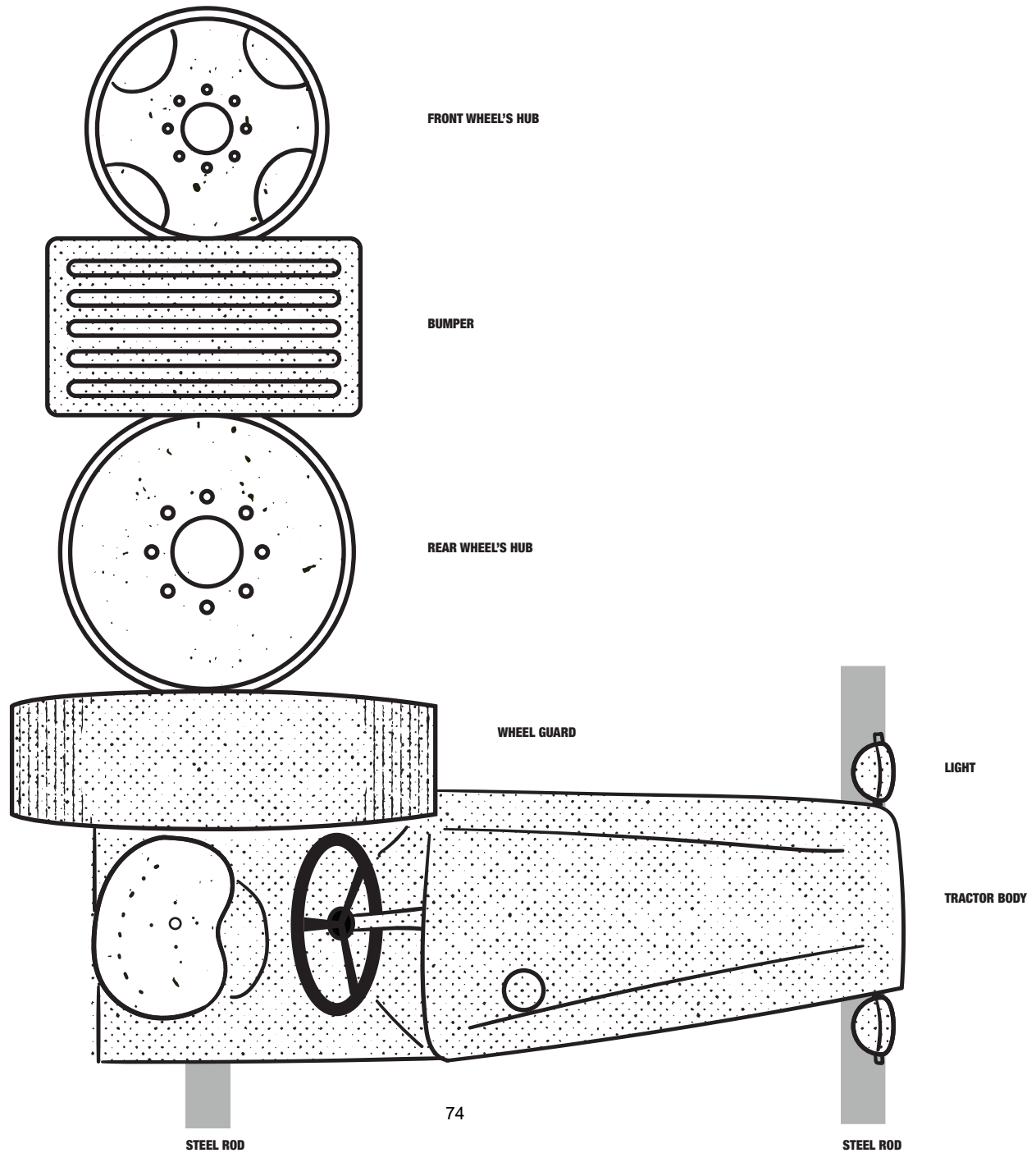

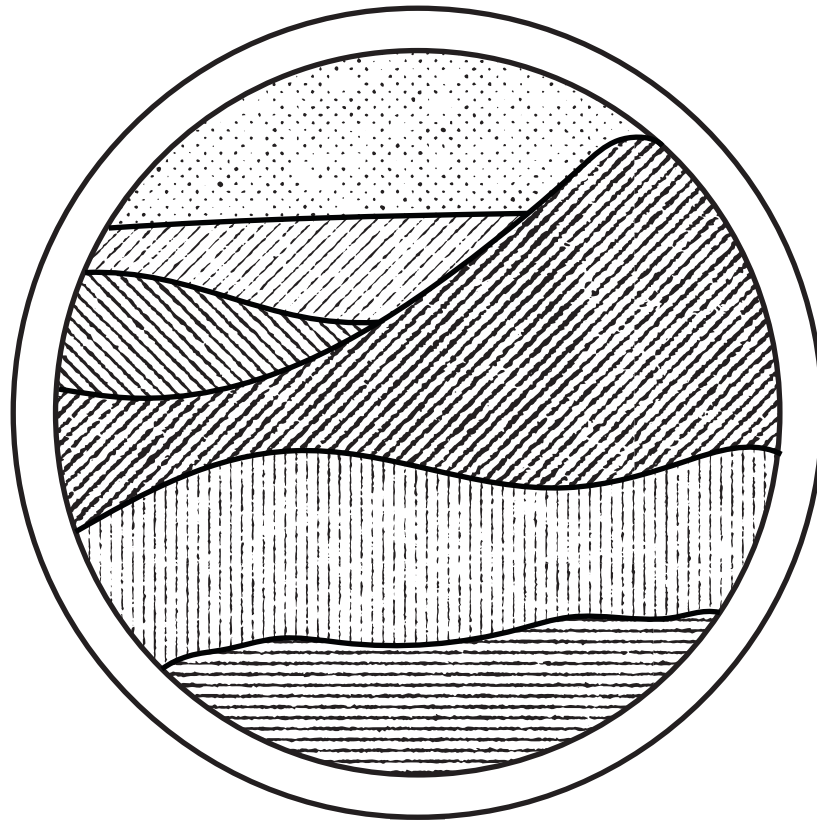

- ALL WOOD
- LASER CUT AND LAYERED/STACKED
- POSSIBLY WITH PATTERNS/GRAINS LASER ENGRAVED
- STAINED DIFFERENT COLORS (GREENS AND BLUES)

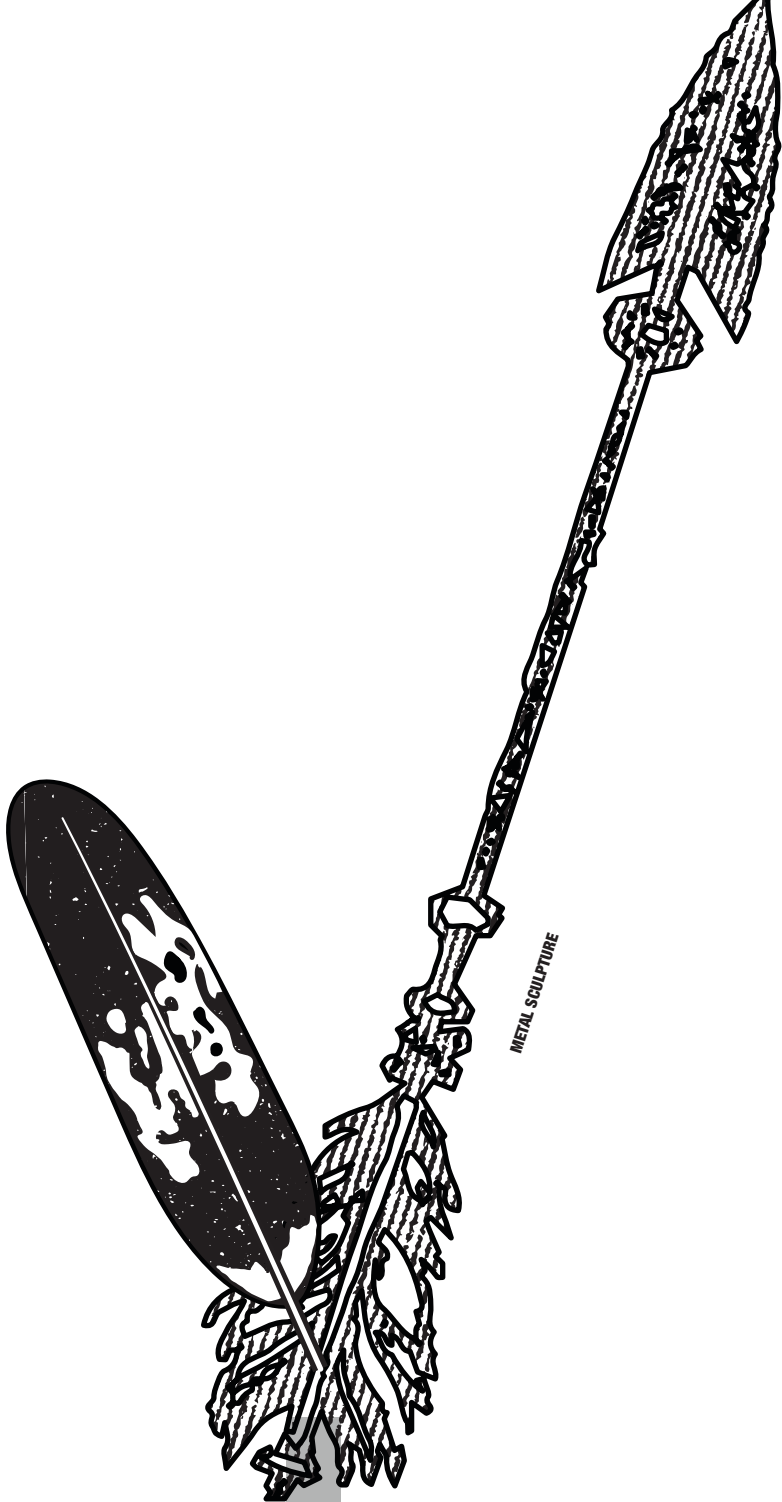

E - BATEAU AND OARS

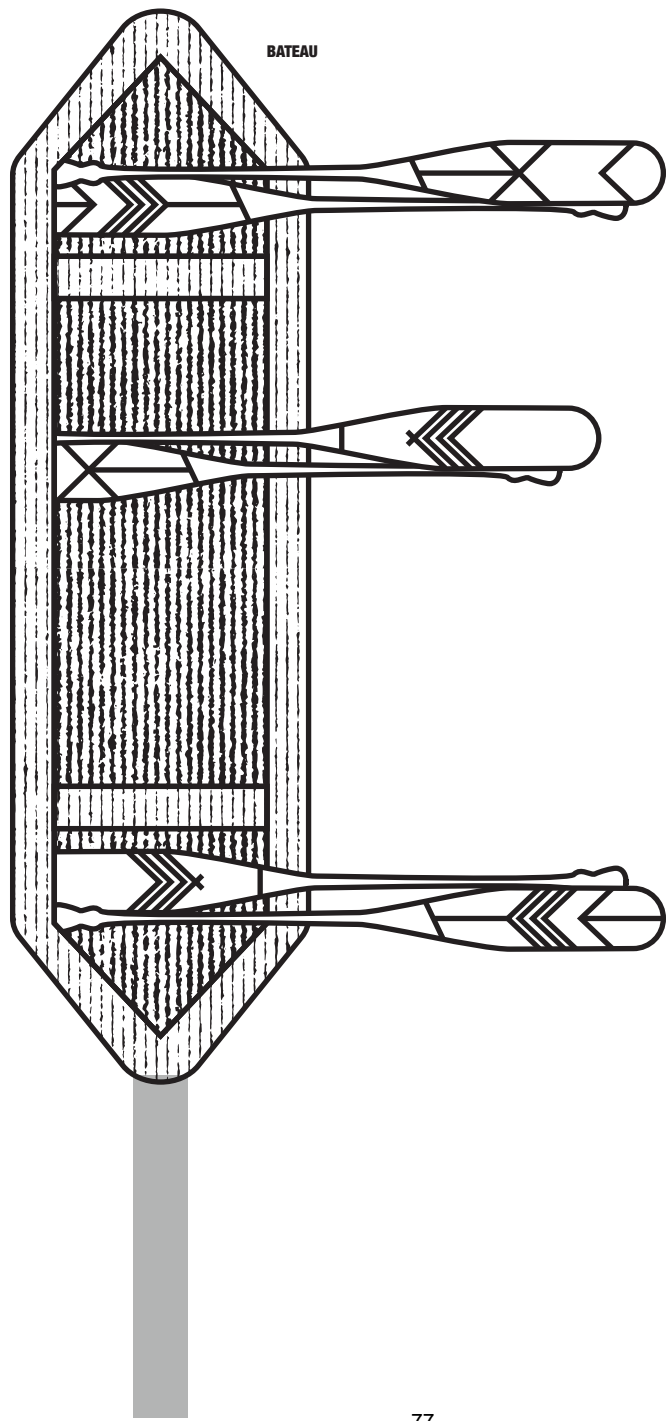

OARS
— POSSIBLY PAINTED WITH SCENES OR PATTERNS

STEEL ROD

FOUNDATION

TOP VIEW

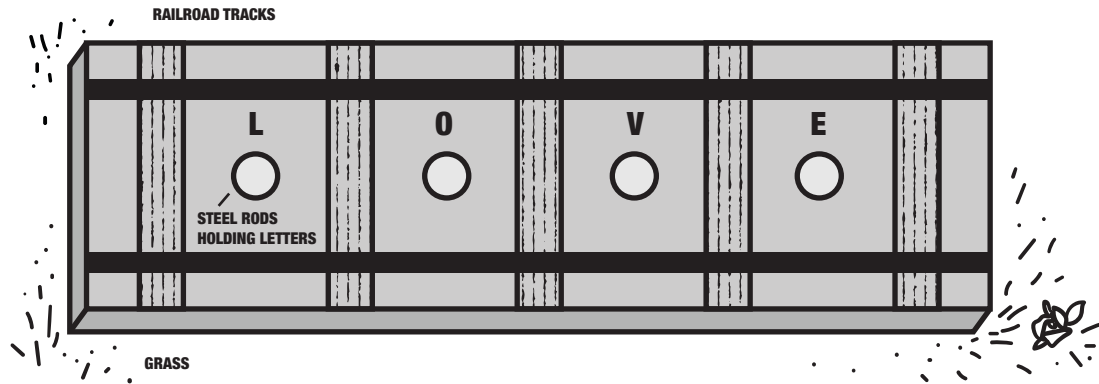

FRONT VIEW

